

Strategies for Compliant Kitchens



Participant Manual



(888) 341-7781 (V/TTY) - Technical Guidance
www.FairHousingFIRST.org

2005-2006



Designed and Developed by:

**The BearingPoint Team
for
U.S. Dept. of Housing and Urban Development
C-OPC-22667
October 2005**

**Government Technical Representative for HUD:
Cheryl Kent, Special Advisor for Disability Policy,
Office of Fair Housing and Equal Opportunity**

The BearingPoint Team

BearingPoint, Inc.

Sara K. Pratt, Civil Rights and
Fair Housing Consultant

Phillip Zook, Phillip Zook Architect

Doug Anderson, LCM Architects

Jack Catlin, LCM Architects

Kate Copeland, Silver State Fair Housing
Council

Rebecca Ingram, Rebecca Ingram Architect

George D. Williams, Diversity Dynamics LLC

William Worn, William Worn Architects, P.C.

Rex Pace, Universal Design Solutions

**Participant Manual
Table of Contents**

Using the Participant Manual	2
Overview of the Fair Housing Act	13
Usable Kitchens Introduction	24
Usable Kitchens	29
Resources	77

Using the Participant Manual

Workbook Layout and Content

As a participant in the course, the Participant Workbook serves as your focal point. It follows the sequence of the class activities and discussion topics. It includes:

- All slides presented by the instructor
- Space for you to take notes
- Key points not contained on slides
- Detailed instructions for exercises
- Resources to supplement the curriculum

To make the Participant Workbook easy to use, the format of each two-page layout is consistent. The left side of the two-page layout is reserved for the slides that the facilitator displays overhead, key points, and space for you to take notes. The right side of the two-page layout contains extra information or topic pointers to further facilitate comprehension of the course material and slides.



Welcome to Fair Housing Accessibility FIRST, a training and technical guidance program created by the U.S. Department of Housing and Urban Development (HUD).

This session is one and a half hours in length.

Fair Housing Accessibility **FIRST**

- Offer training and technical guidance on accessibility requirements of the Fair Housing Act

- Increase the supply of accessible multifamily housing units nationwide

Notes:

Fair Housing Accessibility **FIRST**

- ☐ Gathered opinions and ideas from over 850 stakeholders

Stakeholder Groups

- Builders
- Disability rights advocates
- Government officials
- Trade organizations
- Property managers
- Media
- Code officials
- Enforcement agencies

Notes:

Fair Housing Accessibility **FIRST**

- Comprehensive training curriculum
- Technical guidance via a website and toll free hotline
 - 1-888-341-7781 v/TTY
 - www.FairHousingFIRST.org

Notes:

Strategies for Compliant Kitchens - Introduction

During this training session, we will discuss:

- The specific requirements of Fair Housing Act Requirement 7 - Usable Kitchens and Bathrooms, contained in the Fair Housing Act Accessibility Guidelines
- Specific strategies for creating usable kitchens
- Sample plans for usable kitchens

Notes:

Strategies for Compliant Kitchens - Introduction

During this training session, we will discuss:

- Describe the dimensional specifications and clearances required by Fair Housing Act Requirement 7 – Usable Kitchens and Bathrooms, specifically kitchens
- Identify the elements of kitchen design and construction that are subject to Fair Housing Act specifications and requirements (scoping)
- Identify which other Fair Housing Act requirements apply to kitchens

Notes:

Strategies for Compliant Kitchens - Introduction

During this training session, we will discuss:

- Identify non-compliant elements of kitchen design and construction
- Describe techniques for making various kitchen layouts meet the requirements
- List the available resources to obtain additional information and assist with accessible design and construction questions

Notes:

Name four personal learning goals for this session.

Goals should be:

- S**pecific
- M**easurable
- A**chievable
- R**elevant
- T**imely

Example: I will be able to design two kitchen layouts that comply with the accessibility requirements of the Fair Housing Act.

Strategies for Compliant Kitchens - Introduction

- Small group exercises will be conducted to reinforce key concepts you have learned
- You are encouraged to ask questions throughout the training session
- A questionnaire will be distributed to obtain your feedback on training content, delivery, and materials



Notes:

Who is in your small group?

What are their occupations?

			<h2>Strategies for Compliant Kitchens Agenda</h2> <ul style="list-style-type: none">• Overview of the Fair Housing Act• Usable Kitchens Introduction• Usable Kitchens• Resources
■			
■			
■			

Notes:

History of the Fair Housing Act

- Fair Housing Act was passed in **1968**
Fair Housing Amendments Act, with new coverage of disability, was enacted in **1988**
- Enforced by:
 - The Department of Housing and Urban Development
 - The Department of Justice
 - State and local fair housing enforcement agencies
 - Private lawsuits in federal and state courts



History of the Fair Housing Act

The Fair Housing Act was first passed in 1968, shortly after the assassination of Dr. Martin Luther King, and it prohibited discrimination based on race, color, religion and national origin. Discrimination based on sex was added in 1974. When the law was comprehensively amended in 1988, it was changed to include discrimination against people because of handicap and because of familial status—the presence of children under the age of 18. (During this training, we will refer to the Fair Housing Act’s coverage of handicap discrimination as “disability” protections. “Disability” is the preferred term.)

The Fair Housing Act is enforced administratively by the U.S. Department of Housing and Urban Development (HUD). People who believe that they have been harmed by a violation of the Act may file administrative complaints with HUD, and HUD conducts an impartial investigation of the claims.

The Act also authorizes federal lawsuits by the U.S. Department of Justice, and private lawsuits that can be filed in federal or state courts by individuals. Many state and local fair housing enforcement agencies also have authority to investigate violations and bring enforcement actions. The general authority for all of these enforcement activities is found in the Fair Housing Act. So the enforcement authority given under the Act is quite broad.

History of the Fair Housing Act (continued)

Where violations of the law are established, remedies under the Fair Housing Act may include the award of compensatory damages to victims of discrimination, sometimes numbering in the hundreds of thousands of dollars, orders for comprehensive corrective action, and awards of punitive damages to victims or civil penalties to the government. In design and construction cases, remedies also may require retrofitting housing that has already been constructed to make it comply with the Act's design and construction requirements.

Notes:

Units Covered by the Fair Housing Act

- The design and construction requirements apply to “covered multifamily dwellings” designed and constructed for first occupancy after **March 13, 1991**

- Covered Multifamily Dwellings Include:**
 - All dwelling units in buildings containing four or more units, with an elevator
 - All ground floor units in buildings containing four or more units, without an elevator

Units Covered by the Fair Housing Act

The Fair Housing Act design and construction requirements apply to “covered multifamily dwellings” designed and constructed “for first occupancy” after March 13, 1991.

A building was not designed or constructed for first occupancy if:

- It was occupied on or before March 13, 1991
- If the last building permit or renewal of a building permit was issued on or before June 15, 1990

Buildings where the last building permit was issued on or before June 15, 1990 are not covered by the design and construction requirements. Even if the last building permit was issued after June 15, 1990, if the building was occupied before March 13, 1991, it is not covered. HUD adopted these dates to allow time for the requirements to be considered during the design and construction phase of new properties.

The “first occupancy” language in the statute has been defined in HUD’s Fair Housing Act regulations as “a building that has never before been used for any purpose.” This means buildings that are rehabilitated are not covered by the design and construction requirements even if rehabilitation occurs after March 13, 1991 and even if it is substantial rehabilitation.

Units Covered by the Fair Housing Act (cont)

A dwelling unit includes:

- A single-family unit in buildings with four or more units
- An apartment
- A room in which people sleep even if they share kitchens or bathrooms, like transitional housing

The design and construction requirements apply to “covered multifamily dwellings.” Covered multifamily dwellings are:

1. All dwelling units in buildings containing four or more dwelling units if the buildings have one or more elevators AND
2. All ground floor units in other buildings containing four or more units, without an elevator.

This includes housing that is for rental or for sale and applies whether the housing is privately or publicly funded.

Condominiums and apartment buildings are covered by the design and construction requirements. So are time-shares, dormitories, transitional housing, homeless shelters that are used as a residence, student housing, assisted living housing, and others.

Notes:

Fair Housing Act – Seven Design and Construction Requirements

1. Accessible building entrance on an accessible route
2. Accessible and usable public and common use areas
3. Usable doors
4. Accessible routes into and through covered unit
5. Light switches, electrical outlets, thermostats, and other environmental controls in accessible locations
6. Reinforced walls in bathrooms for later installation of grab bars
7. Usable kitchens and bathrooms



Fair Housing Act – Seven Design and Construction Requirements

The Fair Housing Act's design and construction requirements are broken down into seven basic requirements.

1. Accessible building entrance on an accessible route
2. Accessible and usable public and common use areas
3. Usable doors
4. Accessible routes into and through covered unit
5. Light switches, electrical outlets, thermostats, and other environmental controls in accessible locations
6. Reinforced walls in bathrooms for later installation of grab bars
7. Usable kitchens and bathrooms

The requirements provide for a minimal level of accessibility. Congress, when it passed these requirements, said that it intended that the accessibility provisions of the Fair Housing Act would facilitate the ability of persons with disabilities to enjoy full use of their homes without imposing unreasonable requirements on homebuilders, landlords and residents without disabilities. Congress stated that compliance with these basic requirements would eliminate many of the barriers that discriminate against persons with disabilities in their attempts to have equal housing opportunities.

**Fair Housing Act—Seven Design and Construction Requirements
(continued)**

The design and construction requirements were developed to provide access for people with different types of disabilities. Although some of the requirements focus on people who use wheelchairs, meeting the requirements will also meet the needs of many other people. People who can benefit from accessible features may include people with arthritis or sports injuries who have difficulty turning or gripping door hardware, people who use crutches, canes or walkers, people who because of age or illness have limited mobility or reach ranges, and even people who push strollers, carry groceries, or move furniture. People who have vision or hearing disabilities also benefit from a variety of provisions in the requirements.

Notes:

Fair Housing Act – Seven Design and Construction Requirements (continued)

1. The first is that all covered multifamily dwellings must have ***at least one building entrance on an accessible route*** unless it is impractical to do so because of the terrain or unusual characteristics of the site.
 - An accessible route means a continuous, unobstructed path connecting accessible elements and spaces within a building or site that can be negotiated by a person with a disability who uses a wheelchair, and that is also safe for and usable by people with other disabilities.
 - An accessible entrance is a building entrance connected by an accessible route to public transit stops, accessible parking and passenger loading zones, or public streets and sidewalks.
2. The second requirement is that ***covered housing must have accessible and usable public and common use areas***. Public and common use areas cover all parts of the housing outside individual units. They include, for example: building-wide fire alarms, parking lots, storage areas, indoor and outdoor recreational areas, lobbies, mailrooms and mailboxes, and laundry areas.
3. The third requirement is that all ***doors that allow passage into and within all premises must be wide enough to allow passage by persons using wheelchairs***.
4. The fourth requirement is that ***there must be an accessible route into and through each covered unit***.
5. The fifth requirement is that ***light switches, electrical outlets, thermostats and other environmental controls must be in accessible locations***.
6. The sixth requirement is ***reinforcements in bathroom walls so that grab bars can be added when needed***. The law does not require installation of grab bars in bathrooms.
7. The seventh requirement is that ***kitchens and bathrooms must be usable*** – that is, designed and constructed so an individual in a wheelchair can maneuver in the space provided.

Fair Housing Act – Safe Harbors for Compliance

1. HUD Fair Housing Accessibility Guidelines and the Supplemental Notice
2. ANSI A117.1 (1986), used with the Fair Housing Act, HUD's regulations, and the Guidelines
3. CABO/ANSI A117.1 (1992) used with the Fair Housing Act, HUD's regulations, and the Guidelines
4. ICC/ANSI A117.1 (1998) used with the Fair Housing Act, HUD's regulations, and the Guidelines
5. The Fair Housing Act Design Manual (1998)
6. Code Requirements for Housing Accessibility 2000 (ICC/CRHA)
7. International Building Code 2000 with 2001 Supplement
8. International Building Code 2003, with one condition*

Fair Housing Act – Safe Harbors for Compliance

There are eight safe harbors for compliance with the Fair Housing Act. Compliance with any one of the eight will fulfill the Fair Housing Act's access requirements.

If a particular safe harbor is chosen for use in a particular property, housing must comply with all of the provisions of that safe harbor in order for there to be a safe harbor. So it is unwise to pick and choose among the provisions of different safe harbor standards.

These are the eight access standards that HUD has identified as safe harbors:

1. *The Fair Housing Act Accessibility Guidelines* (issued on March 6, 1991), and the Supplemental Notice to Fair Housing Accessibility Guidelines: Questions and Answers about the Guidelines (issued June 28, 1994).
2. *ANSI A117.1 (1986)*, used with the Fair Housing Act, HUD's Fair Housing Act regulations, and the Guidelines.
3. *CABO/ANSI A117.1 (1992)*, used with the Fair Housing Act, HUD's Fair Housing Act regulations, and the Guidelines.
4. *ICC/ANSI A117.1 (1998)*, used with the Fair Housing Act, HUD's Fair Housing Act regulations, and the Guidelines.

**Fair Housing Act –
Safe Harbors for Compliance (continued)**

5. *The Fair Housing Act Design Manual (1998).*
6. *Code Requirements for Housing Accessibility 2000 (CRHA)*, published by the International Code Council in October, 2000.
7. *International Building Code 2000 (IBC)*, as amended by the IBC's 2001 Supplement to the International Codes.
8. *International Building Code 2003(IBC)*, with one condition.*

- * Effective February 28, 2005 HUD determined that the IBC 2003 is a safe harbor, conditioned upon ICC publishing and distributing a statement to jurisdictions and past and future purchasers of the 2003 IBC stating, "ICC interprets Section 1104.1, and specifically, the exception to Section 1104.1, to be read together with Section 1107.4, and that the Code requires an accessible pedestrian route from site arrival points to accessible building entrances, unless site impracticality applies. Exception 1 to Section 1107.4 is not applicable to site arrival points for any Type B dwelling units because site impracticality is addressed under Section 1107.7."

It is important to note that the ANSI A117.1 standard contains only technical criteria, whereas the Fair Housing Act, the regulations and the Guidelines contain both scoping and technical criteria. Therefore, in using any of the ANSI standards it is necessary to also consult the Act, HUD's regulations, and the Guidelines.

Other means of providing access that provide an equal or greater degree of accessibility may also be used to comply with the Fair Housing Act's access requirements, but they are not a safe harbor.

This training relies on the provisions of the Fair Housing Act, the Guidelines and Supplemental Questions and Answers, ANSI A117.1 (1986) and the Fair Housing Act Design Manual for the guidance that it provides about compliance with the technical design and construction requirements in the Act.

Notes:

CAUTION:

Safe harbor standards constitute safe harbors only when adopted and implemented in accordance with the policy statement that HUD published in the Federal Register on March 23, 2000. That policy statement notes, for example, that if a jurisdiction adopts a model building Code that HUD has determined conforms with the design and construction requirements of the Act, then covered residential buildings that are constructed in accordance with plans and specifications approved during the building permitting process will be in compliance with the requirements of the Act unless the building code official has waived one or more of those requirements or the building code official has incorrectly interpreted or applied the building code provisions. In addition, adoption of a HUD recognized safe harbor does not change HUD's responsibility to conduct an investigation if it receives a complaint.

Strategies for Compliant Kitchens		
■		
		• Overview of the Fair Housing Act
		• Usable Kitchens and Bathrooms – Requirement 7
■		
		• Usable Kitchens
		• Usable Bathrooms
■		

Notes:

Refer to Chapter 7 of the Fair Housing Act Design Manual.

Usable Kitchens Introduction



Usable Kitchens Introduction

Kitchens designed to comply with the Fair Housing Act Accessibility Guidelines (Guidelines) provide a basic level of accessibility for a person using a wheelchair to maneuver about the space, approach and use the appliances and fixtures.

Kitchens designed to comply with the Guidelines do not differ in appearance from conventional kitchen designs typically seen in multi-family housing types.

Notes:

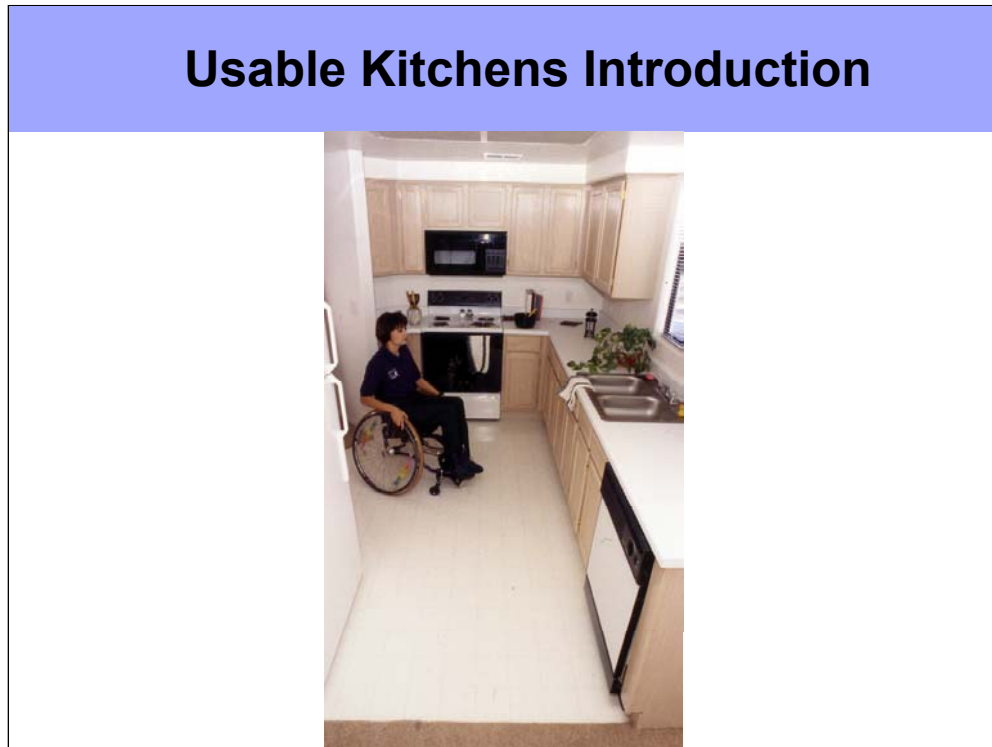

Usable Kitchens Introduction

The specifications in the Guidelines for kitchens do not provide full accessibility.

For instance, the Guidelines do not require a 60" turning space in kitchens except in certain designs. The Guidelines also do not require clear floor space under sinks, nor do they require lowered work surfaces in the kitchen.

However, the minimum specifications in the Guidelines do require a basic level of accessibility, which, along with residents' rights to make further modifications, achieves significantly more accessibility in kitchens.

Notes:

Usable Kitchens Introduction– 30”x48” Clear Floor Space

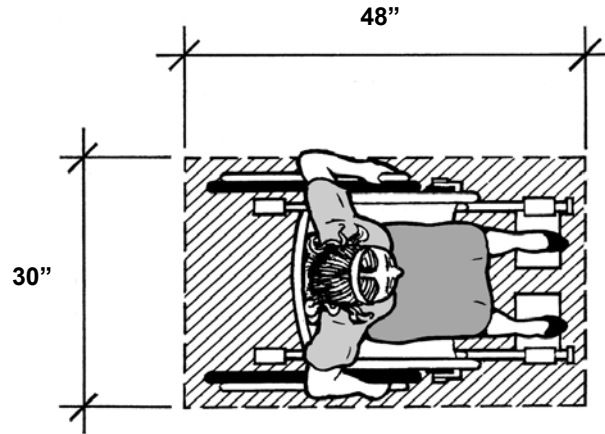

Usable Kitchens Introduction– 30”x48” Clear Floor Space

In kitchens, the basic building block of space used in the Guidelines is a **30”x48” clear floor space**. This is the standard in ANSI, ADAAG and other accessibility standards.

A 30”x48” clear floor space is the approximate space occupied by an average size person in a conventional manual wheelchair.

Clear floor spaces for fixtures and appliances may overlap.

The 30”x48” clear floor space must be positioned for either a parallel or forward approach.

Notes:

Usable Kitchens Introduction – Clear Floor Space



Usable Kitchens Introduction– Clear Floor Space

Clear floor space and other maneuvering space requirements discussed in this module allow persons using wheelchairs and other mobility aides to approach and use the fixtures and appliances.

Notes:

Strategies for Compliant Kitchens		
		• Overview of the Fair Housing Act
		• Usable Kitchens Introduction
		• Usable Kitchens
		– General Requirements
		– Clear Floor Space
		– Clearance Between Countertops
		– Clearance in U-Shaped Kitchens
		– Adaptable Cabinets
		– Sample Designs
		• Resources

Notes:

Refer to page 7.3 of the Fair Housing Act Design Manual.

Usable Kitchens



General Requirements:

- Clear floor space at appliances
- Clearance between countertops, appliances, and walls
- Maneuvering space in U-shaped kitchens

Notes:

General Requirements for Usable Kitchens

One 30"x48" clear floor space at each fixture and appliance (clear floor areas may overlap)

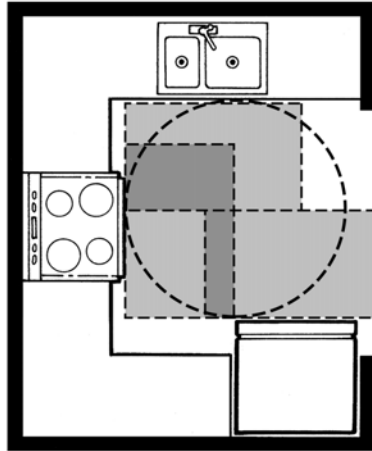

General Requirements for Usable Kitchens

In addition to meeting all the clear floor space and clearance requirements, kitchens must also meet the other applicable requirements:

- Have usable doors, if applicable, Requirement 3 – Usable Doors
- Be on an accessible route, Requirement 4 – Accessible Route into and Through the Unit
- Have outlets and switches in usable locations, Requirement 5 – Outlets, Switches, and Other Environmental Controls in Usable Locations

Notes:

Strategies for Compliant Kitchens		
		• Overview of the Fair Housing Act
		• Usable Kitchens Introduction
		• Usable Kitchens
		– General Requirements
		– Clear Floor Space
		– Clearance Between Countertops
		– Clearance in U-Shaped Kitchens
		– Adaptable Cabinets
		– Sample Designs
		• Resources

Notes:

Refer to page 7.3 of The Fair Housing Act Design Manual.

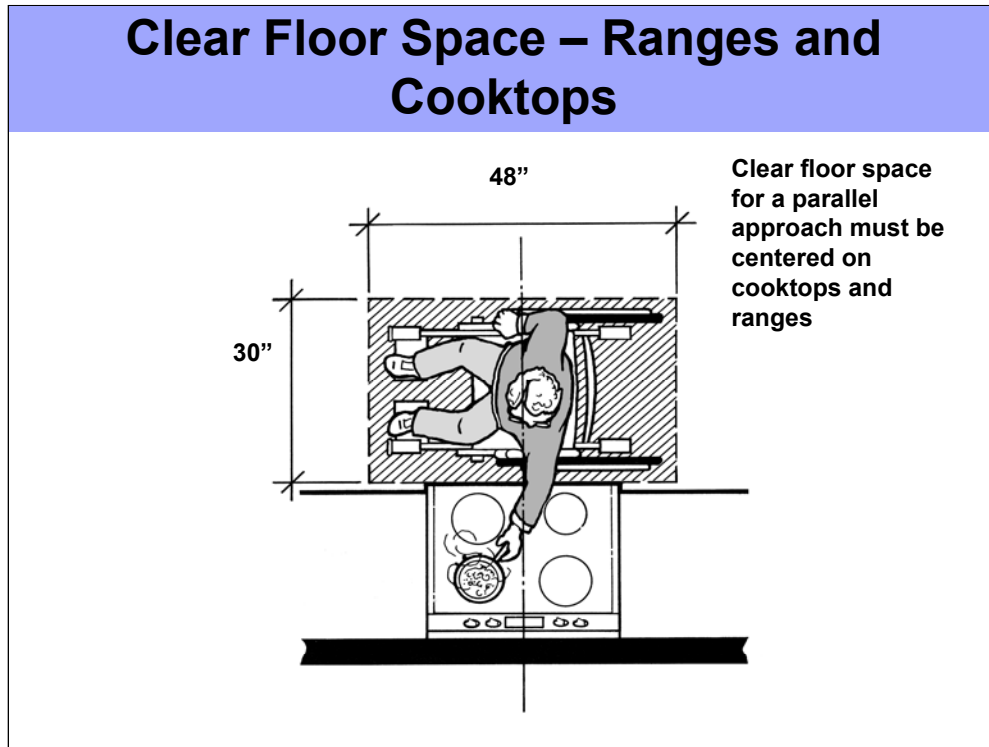

Clear Floor Space – Ranges and Cooktops

The Guidelines specify a **30"x48" clear floor space** at cooktops and ranges. The clear floor space must be parallel to and centered on the range or cooktop.

The clear floor space in this parallel and centered orientation allows a person using a wheelchair to make a close side approach, permitting a safer and shorter reach to controls and items on the burners.

A cooktop may be designed with knee space below, and with the 30"x48" clear floor space oriented for a forward approach.

Clear Floor Space – Ranges and Cooktops

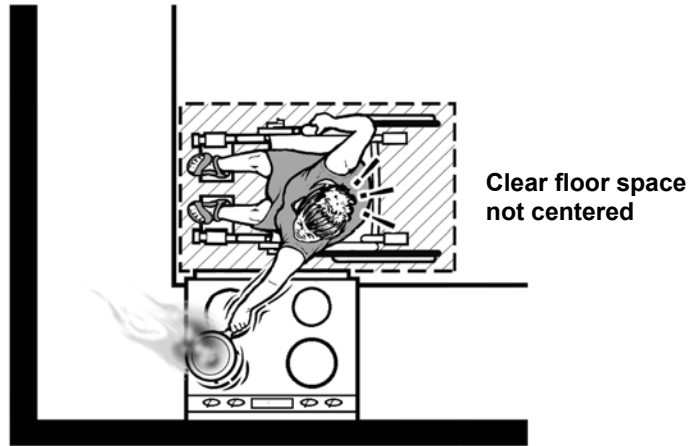

Not Allowed

Clear Floor Space – Ranges and Cooktops Incorrect Floor Space

If the 30"x48" clear floor space is not centered, a person attempting a side approach will not have a full range of motion for side reach tasks. The person may have to lean and reach excessively to use the controls and cook surfaces, making use of the appliance difficult and unsafe.

Notes:

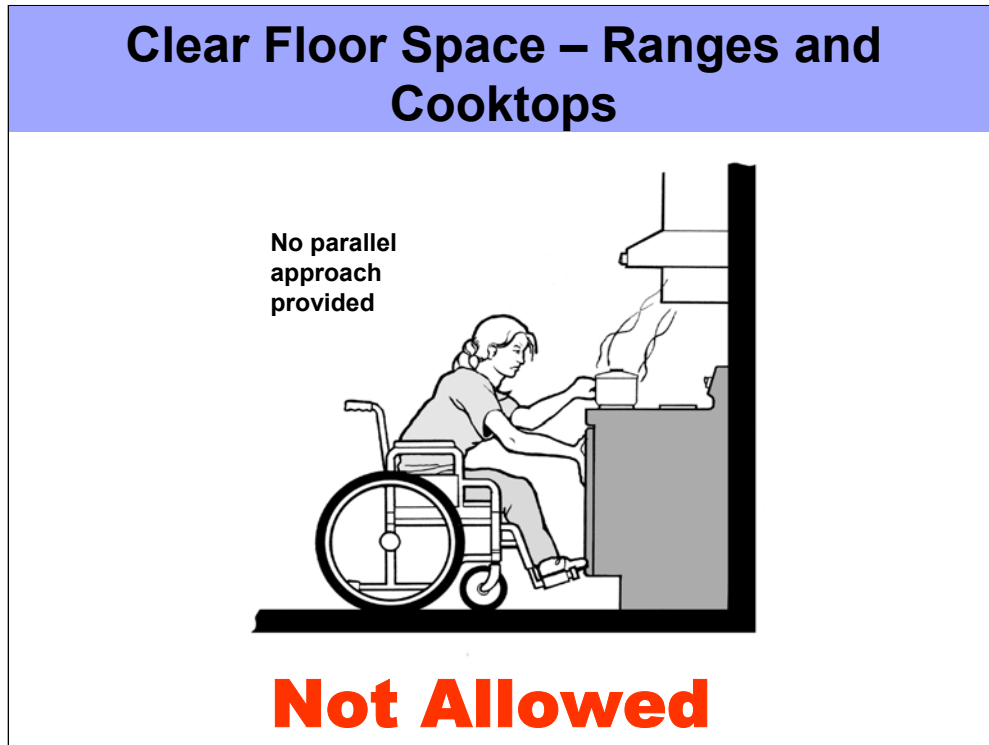

**Clear Floor Space – Ranges and Cooktops
Incorrect Floor Space**

Likewise, when only a forward approach (without knee space) is provided, such as in this narrow kitchen, excessive reaching required to operate the controls and tend items on the cooking surface is difficult and unsafe. A design that provides only a forward approach at ranges and cooktops is not allowed.

Notes:

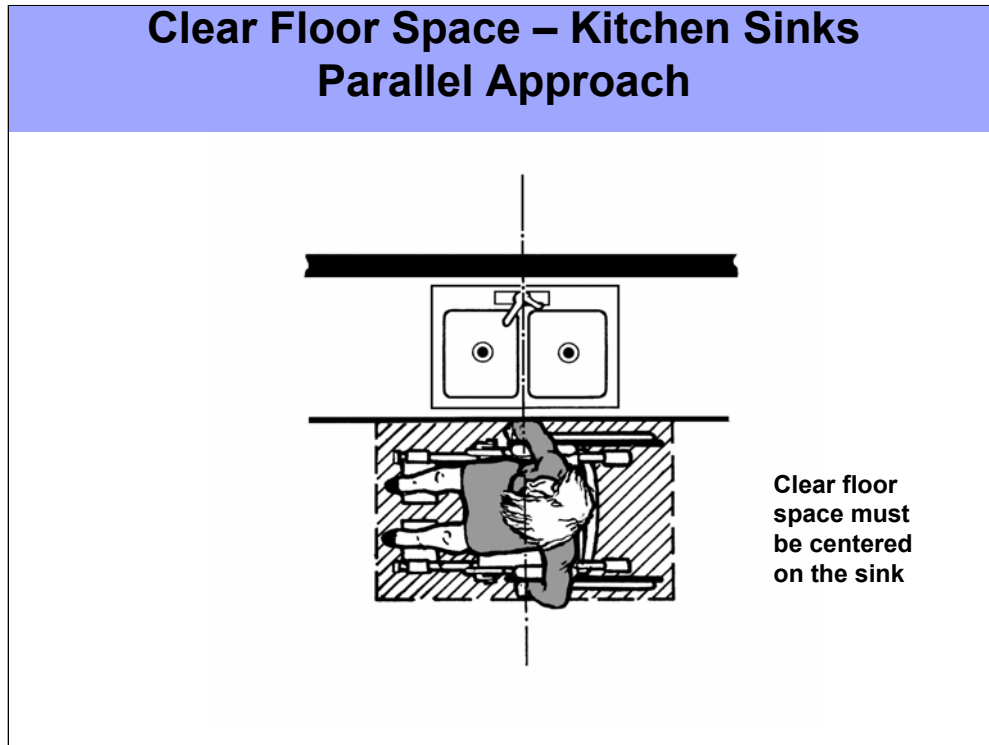

Clear Floor Space – Kitchen Sinks Parallel Approach

The Guidelines also specify a **30"x48" clear floor space at kitchen sinks**. The clear floor space must be parallel to and centered on the kitchen sink.

The clear floor space in this parallel and centered orientation allows a person using a wheelchair to make a close side approach, permitting a reach to the faucets, to easily wash dishes or food without excessive twisting in the wheelchair.

A sink may also be designed with knee space below, with the 30"x48" clear floor space oriented for a forward approach.

Notes:

Clear Floor Space – Kitchen Sinks

Clear floor
space is not
centered

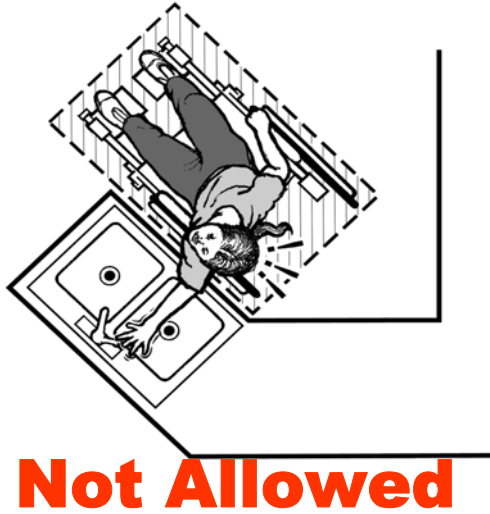

Clear Floor Space – Kitchen Sinks Incorrect Floor Space

If an obstruction, such as an adjacent cabinet in this illustration, does not permit a parallel and centered approach, the person may not be able to use the sink or reach and use the faucets.

Notes:

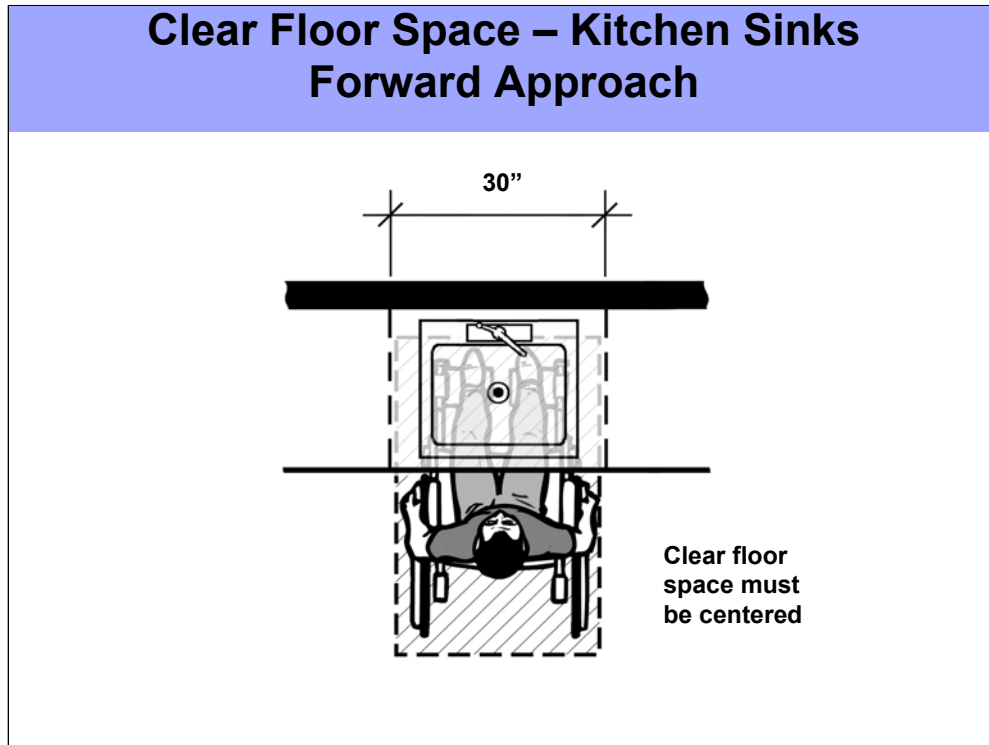

Clear Floor Space – Kitchen Sinks Forward Approach

A forward approach to the kitchen sink is allowed if knee space is provided under the sink. The 30"x48" clear floor space for a forward approach must be centered and extend under the sink a maximum of 19".

A conventional appearance, identical to kitchens which do not have knee space, can be achieved by providing an adaptable sink-base cabinet. Adaptable cabinets will be discussed later in this presentation.

Notes:

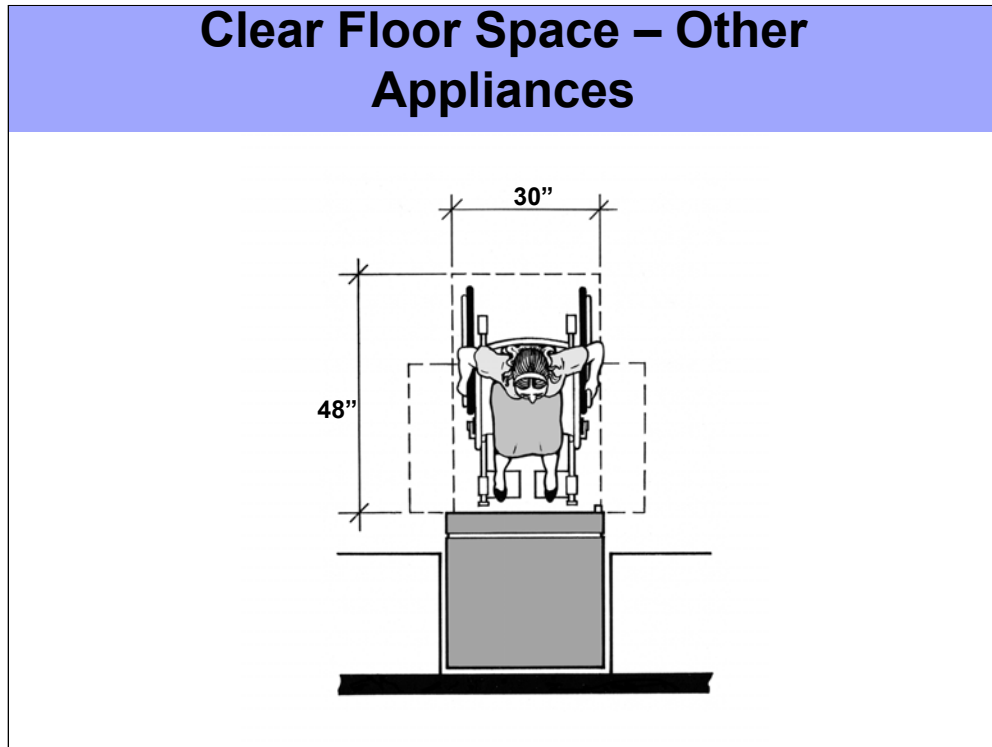

Clear Floor Space – Other Appliances

A 30"x48" clear floor space, parallel or forward, is required to be positioned at ovens, dishwashers, refrigerators and freezers, and trash compactors. When either a parallel or forward approach is utilized, it must be centered on the appliance.

Even though this group of appliances has operable doors that require a user to be outside the swing of the door to use the appliance, for purposes of design and room layout, the clear floor space must be centered in front of the appliance.

Notes:

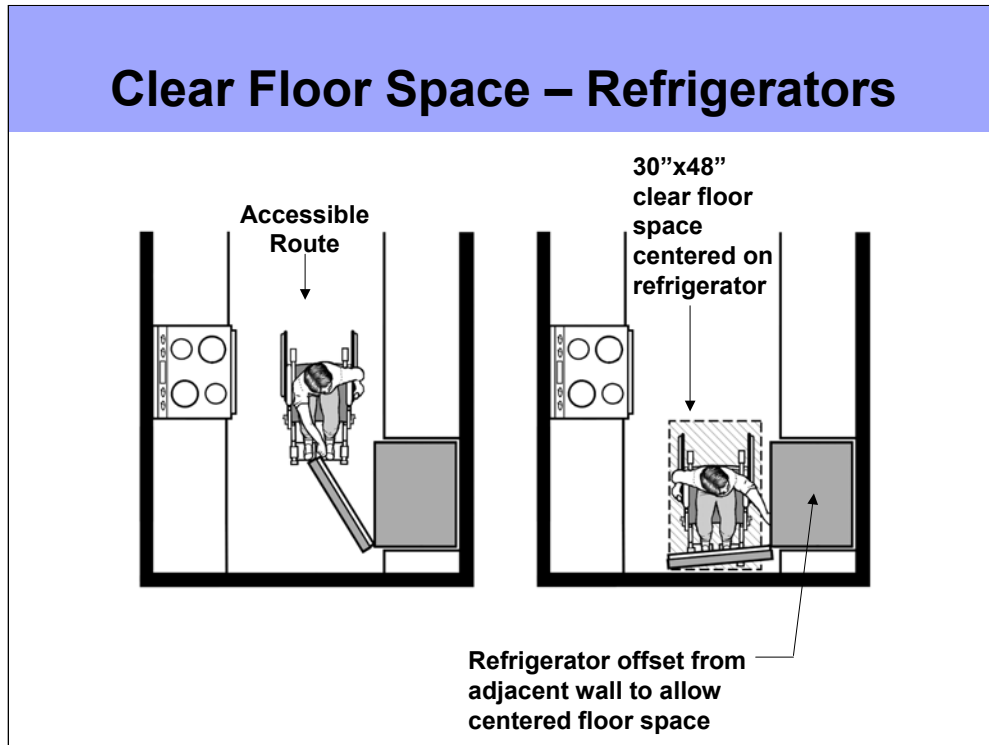

Clear Floor Space - Refrigerators

For instance, in this galley kitchen design, a refrigerator is shown close to an adjacent sidewall. The clearance between cabinets, which will be discussed later, allows a person to approach the refrigerator and open the door while positioned outside the swing of the door.

Also, in this design, there must be a 30"x48" clear floor space area parallel-to and centered-on the refrigerator which requires the refrigerator door to swing open slightly more than 90 degrees, permitting a person in a wheelchair to make a close parallel approach and reach items in the refrigerator.

Notes:

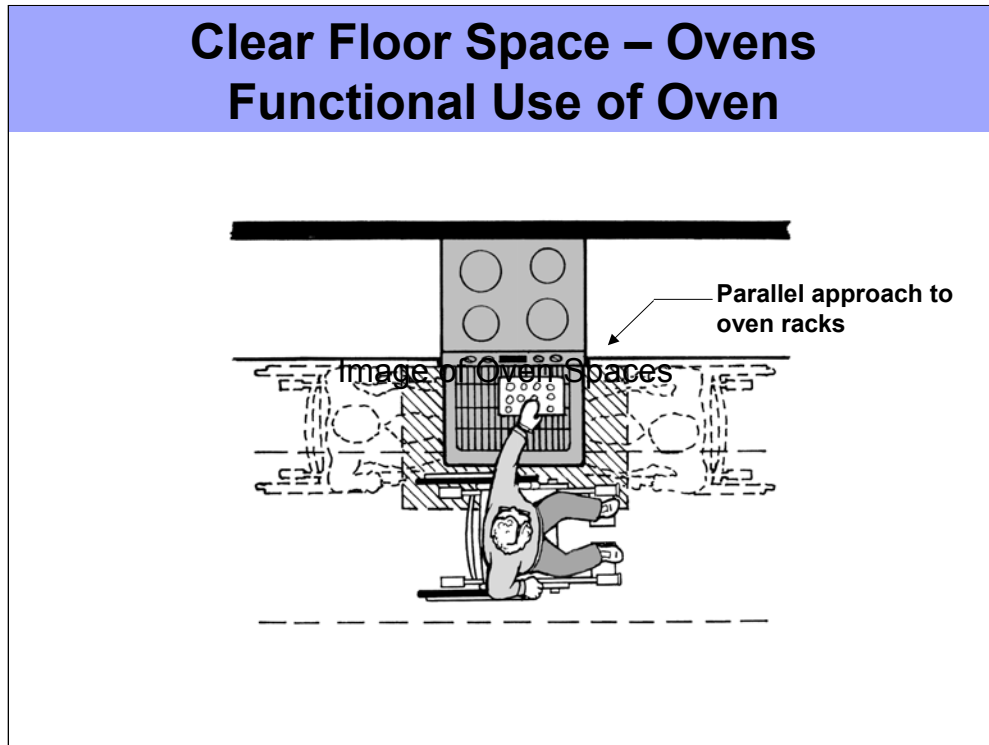

Clear Floor Space – Ovens Functional Use of Oven

Ovens are one of a group of appliances that have operable doors which require the user to get out of the way of the door-swing to use the appliance. For purposes of design and kitchen layout, the required 30"x48" clear floor space must be centered on the appliance. Functional space necessary to open the door and access the racks of the oven are achieved when all of the maneuvering space requirements are met:

- 36" accessible route into the kitchen (Req. 4)
- Clear floor space at appliances (Req. 7)
- Clearance between countertops (Req. 7)
- 60" diameter maneuvering space in U-shaped kitchens when a sink, range, or cook top is located at the base of the U (Req. 7)

Strategies for Compliant Kitchens		
		Overview of the Fair Housing Act
		Usable Kitchens Introduction
		Usable Kitchens
		– General Requirements
		– Clear Floor Space
		– Clearance Between Countertops
		– Clearance in U-Shaped Kitchens
		– Adaptable Cabinets
		– Sample Designs
		Resources

Notes:

Refer to page 7.7 of the Fair Housing Act Design Manual.

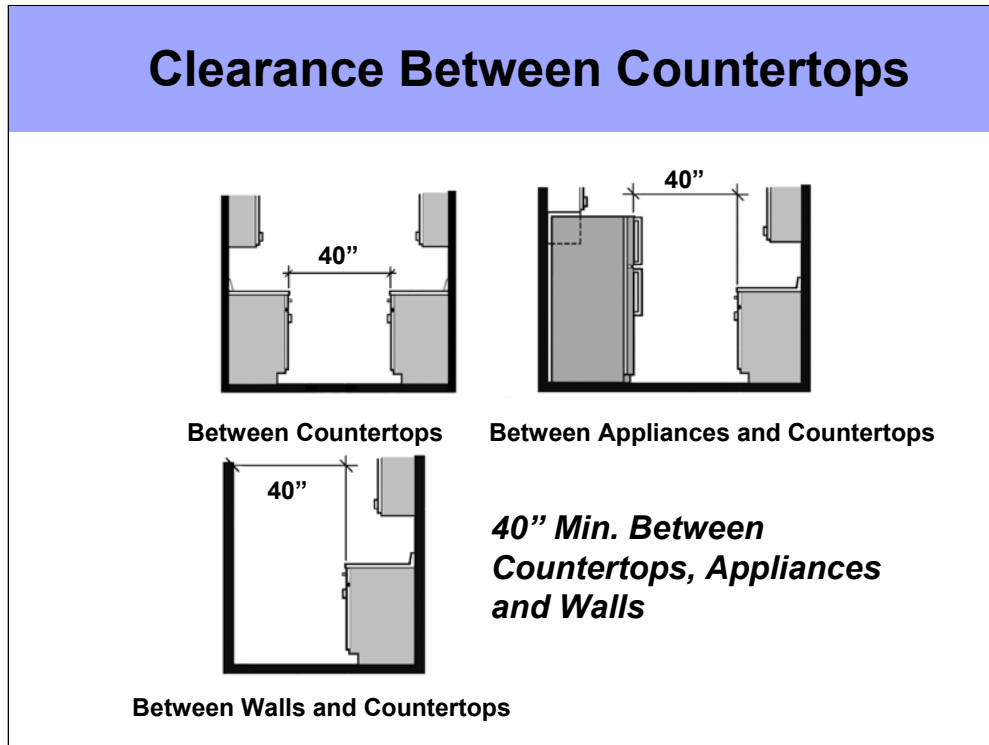

Clearance Between Countertops

A **minimum clearance of 40"** must be provided between all opposing countertops, appliances, and walls.

The clearance provided must be measured from:

- Countertop edge to opposing countertop edge.
- Countertop edge to face of opposing appliance. (Handles of appliances are allowed to overlap into clearance.)
- Countertop edge to opposing face of wall.
- If there is a cabinet without a countertop such as a full-length pantry cabinet, the clearance must be provided between the face of the cabinet and the opposing countertop, appliance, or wall.

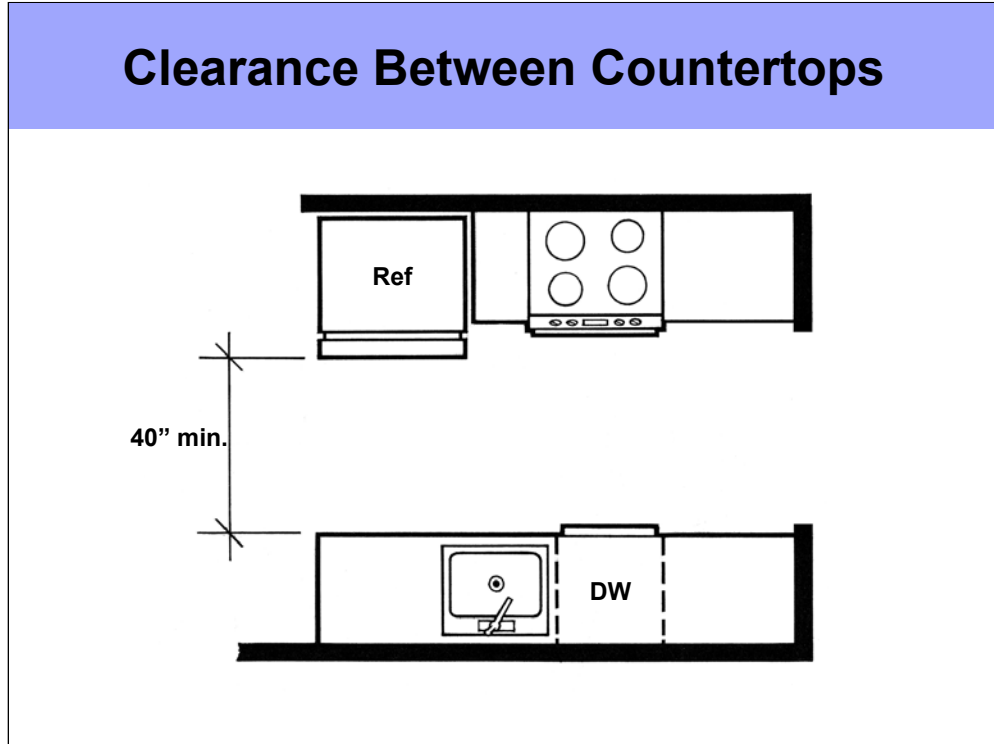

Clearance Between Countertops

Care must be exercised when designing kitchens because appliances such as refrigerators and ranges generally extend beyond the standard 25" countertop. In a galley style kitchen, the 40" clearance must be maintained between the opposing countertop and the protruding appliance.

Notes:

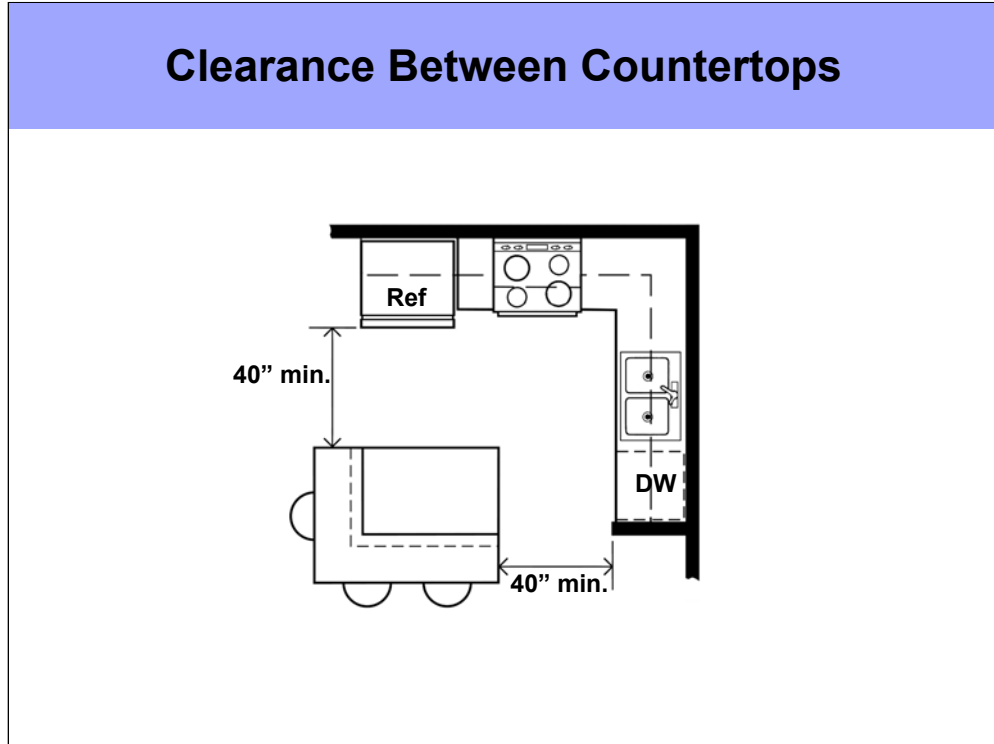

Clearance Between Countertops

Likewise at islands, a **minimum of 40"** must be maintained between the edge of the island countertop and any opposing countertops, appliances, and walls.

Notes:

Strategies for Compliant Kitchens		
		• Overview of the Fair Housing Act
		• Usable Kitchens Introduction
		• Usable Kitchens
		– General Requirements
		– Clear Floor Space
		– Clearance Between Countertops
		– Clearance in U-Shaped Kitchens
		– Adaptable Cabinets
		– Sample Designs
		• Resources

Notes:

Refer to page 7.9 of the Fair Housing Act Design Manual.

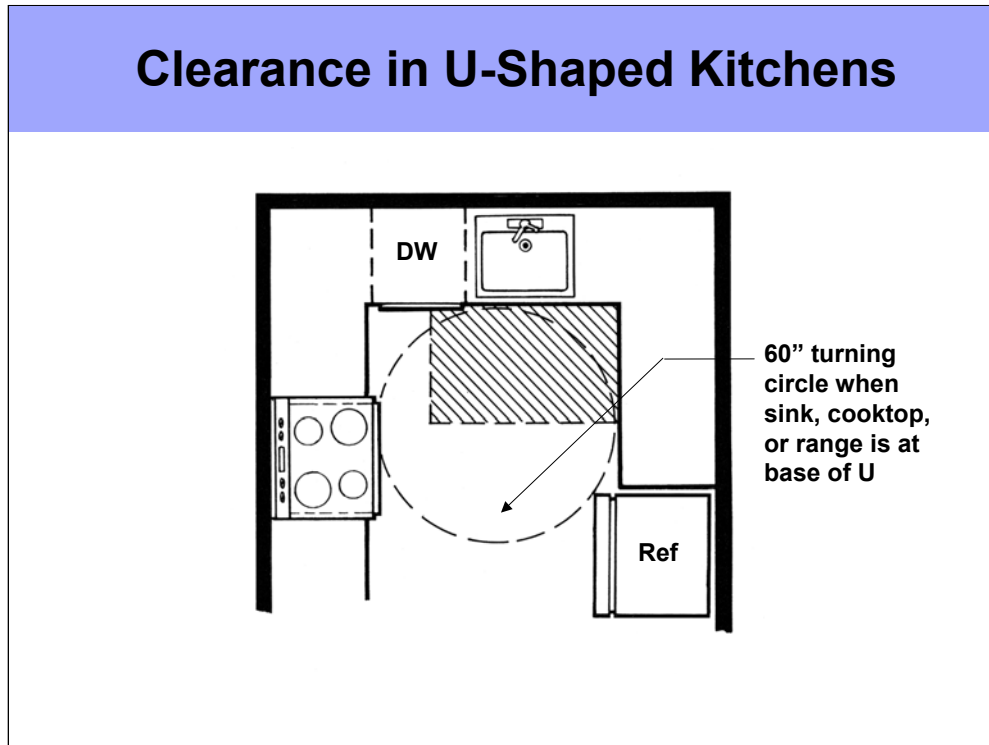

Clearance in U-Shaped Kitchens

In U-shaped kitchens where the sink, range, or cooktop is located at the base of the U, there must be an unobstructed **60" diameter maneuvering space**.

As in a galley kitchen, extra depth of appliances such as refrigerators and ranges must not overlap required maneuvering space.

A U-shaped kitchen that does not have a sink, range or cooktop at the base of the U is not required to have a 60" maneuvering space. However, there must be a minimum of 40" between opposing cabinets, countertops, appliances, and walls, and there must be compliant clear floor space at all appliances.

Clearance in U-Shaped Kitchens



Clearance in U-Shaped Kitchens

In the U-shaped kitchen pictured here, the presence of a 60" maneuvering space within the kitchen allows this person to maneuver and position her wheelchair to make a close parallel approach to the range.

Notes:

Clearance in U-Shaped Kitchens



Clearance in U-Shaped Kitchens

Likewise, the 60" maneuvering space permits a person using a wheelchair to maneuver and position the wheelchair for a close parallel approach to the other fixtures including the sink.

Notes:

Clearance in U-Shaped Kitchens



Clearance in U-Shaped Kitchens

Likewise, the 60" maneuvering space permits a person using a wheelchair to maneuver and position the wheelchair for a close parallel approach to the other fixtures including the refrigerator.

Notes:

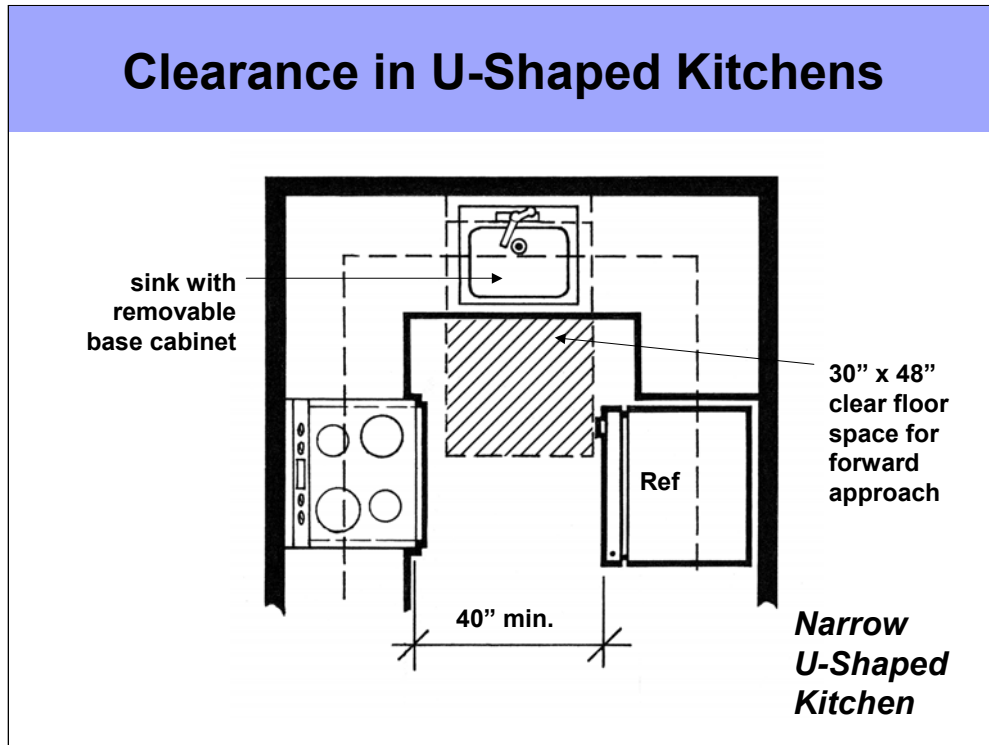

Clearance in U-Shaped Kitchens Exception

The Guidelines permit a U-shaped kitchen (with a sink or cooktop at the base of the U) to have less than 60" between the legs of the U only when knee space is provided under the sink or cooktop. If permanent knee space is not provided, an easily adaptable cabinet could be provided under the sink or cooktop.

The minimum maneuvering space at the other appliances must be maintained and in no case may clearance between opposing cabinets, countertops, appliances, and walls be less than 40". These clearances must be maintained even if there is not a sink or cooktop at the base of the U.

Lastly, if the base of the U does not have a sink, cooktop or range, the clearance between the opposing countertops or appliances may be 40".

Strategies for Compliant Kitchens		
		• Overview of the Fair Housing Act
		• Usable Kitchens Introduction
		• Usable Kitchens
		– General Requirements
		– Clear Floor Space
		– Clearance Between Countertops
		– Clearance in U-Shaped Kitchens
		– Adaptable Cabinets
		– Sample Designs
		• Resources

Notes:

Refer to page 7.12 of the Fair Housing Act Design Manual.

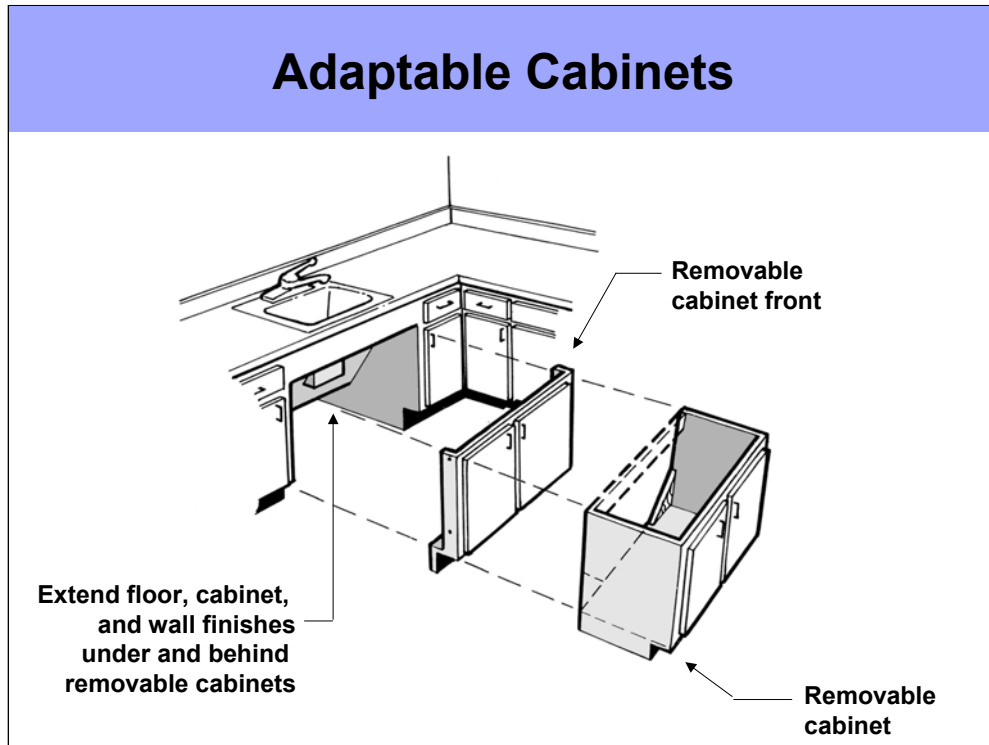

Adaptable Cabinets

The required 30"x48" clear floor space at sinks and cooktops can be positioned for a forward approach to the fixture if knee space is provided.

If a knee space design is not desired, an alternative is to provide a conventional cabinet that is designed to be quickly and easily adaptable to create knee space.

If an adaptable cabinet solution is used, it should be designed so the accessible version is equal in quality of finishes to the conventional version without knee space. The finish floor must extend under the sink. The ends of adjacent cabinets and the rear wall under the sink must also be finished. Although not required, pipe protection under the sink is strongly recommended.

Adaptable cabinet solutions include cabinets with retractable doors, cabinets with removable fronts and cabinets that are easily removable.



Adaptable Cabinets

The photograph above is a good example of a successful adaptable cabinet.

The doors and frame of the cabinet are mounted to the adjacent cabinet with demountable hardware that allow the front to be removed in minutes by simply removing a few screws concealed on the inside face of the cabinet frame.

Notes:



Adaptable Cabinets

When the front is removed, note that the quality of finishes of the accessible version are equal to the conventional version without knee space.

The finish floor extends under the sink, the end-panels of the adjacent cabinets are finished and the underside of the sink and pipes are concealed with an attractive cover that matches the cabinets.

Although not required, an important function of concealing the pipes is that inadvertent burns to the limbs of people with decreased sensation can be avoided.

Notes:

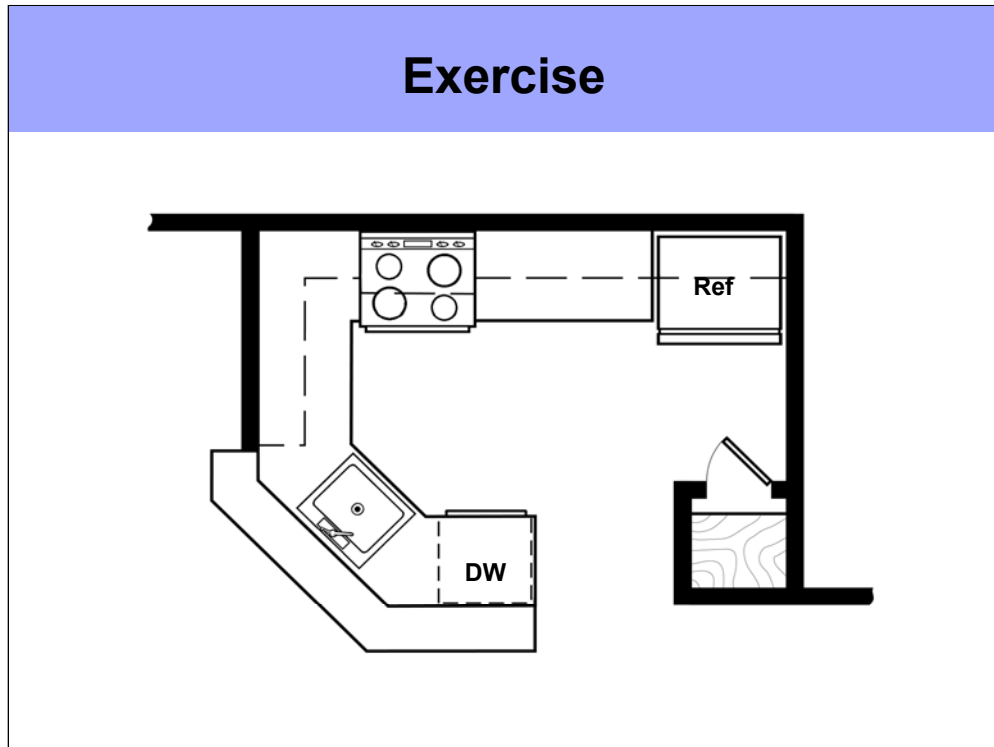

Exercise – Usable Kitchens

Exercise Objective:

The objectives for this exercise are:

- To test your understanding of some of the terms and concepts presented in this module.
- To test your understanding of some of the basic features of accessibility required under Requirement 7 – Usable Kitchens and Bathrooms.
- To acquire some basic experience in reviewing a floor plan and identifying non-compliant accessibility features required.

Exercise Assignment:

Analyze and identify the non-compliant features of the plans on the following pages with your small group.

Exercise – Image #1

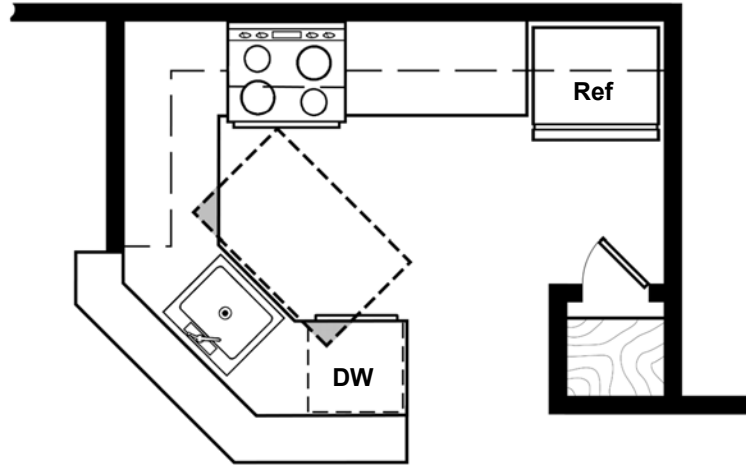

Non-Compliant Features

Exercise – Image #2

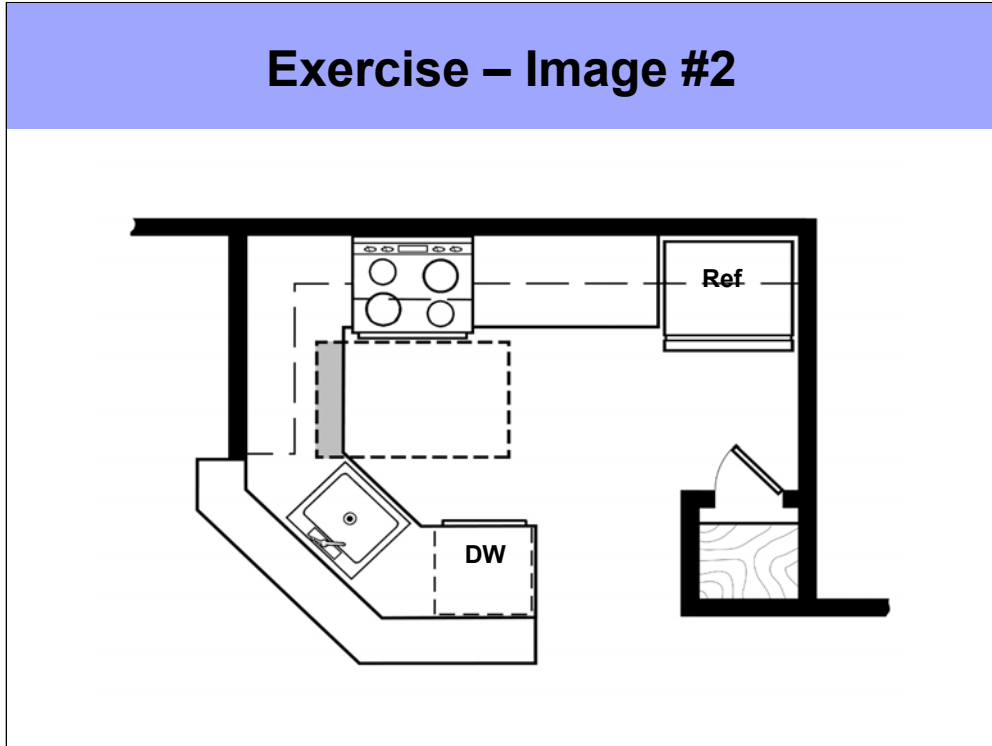

Non-Compliant Features

Exercise – Image #3

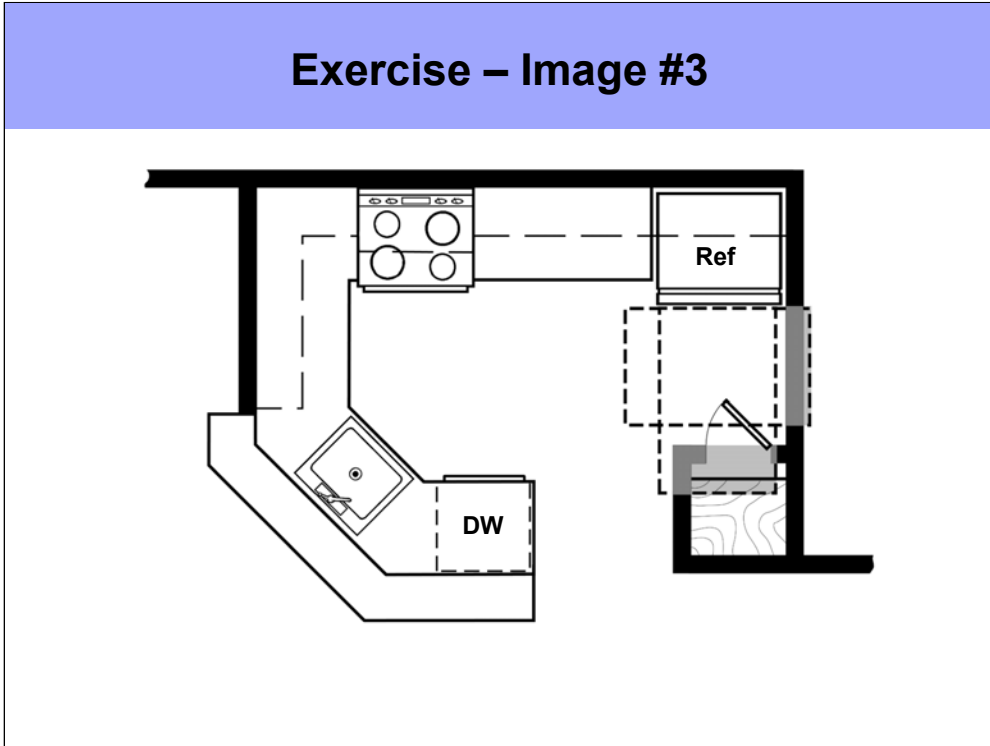

Non-Compliant Features

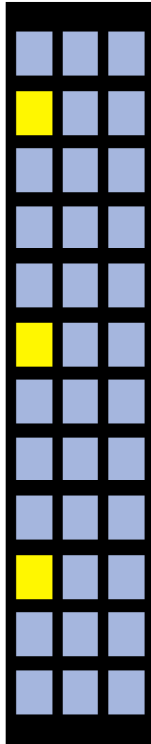

Strategies for Compliant Kitchens

- Overview of the Fair Housing Act
- Usable Kitchens Introduction
- **Usable Kitchens**
 - General Requirements
 - Clear Floor Space
 - Clearance Between Countertops
 - Clearance in U-Shaped Kitchens
 - Adaptable Cabinets
 - **Sample Designs**
- Resources

Notes:

Refer to page 7.22 of the Fair Housing Act Design Manual.

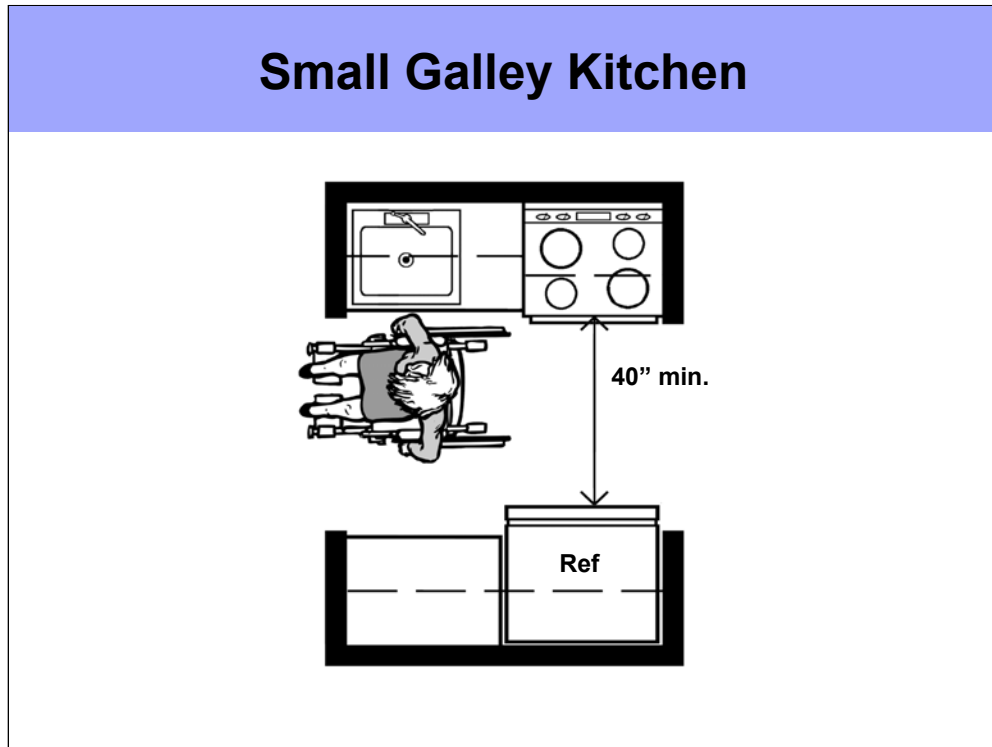

Small Galley Kitchen

Depicted above is a small galley kitchen design you might find in an apartment, efficiency, dormitory or single room occupancy unit.

In this design, the minimum distance between the face of the refrigerator and range must be no less than 40". The resultant distance between countertops would be greater than the 40" minimum.

Designers must anticipate the depths of appliances when designing kitchens that comply with the clearance requirements between countertops.

Notes:

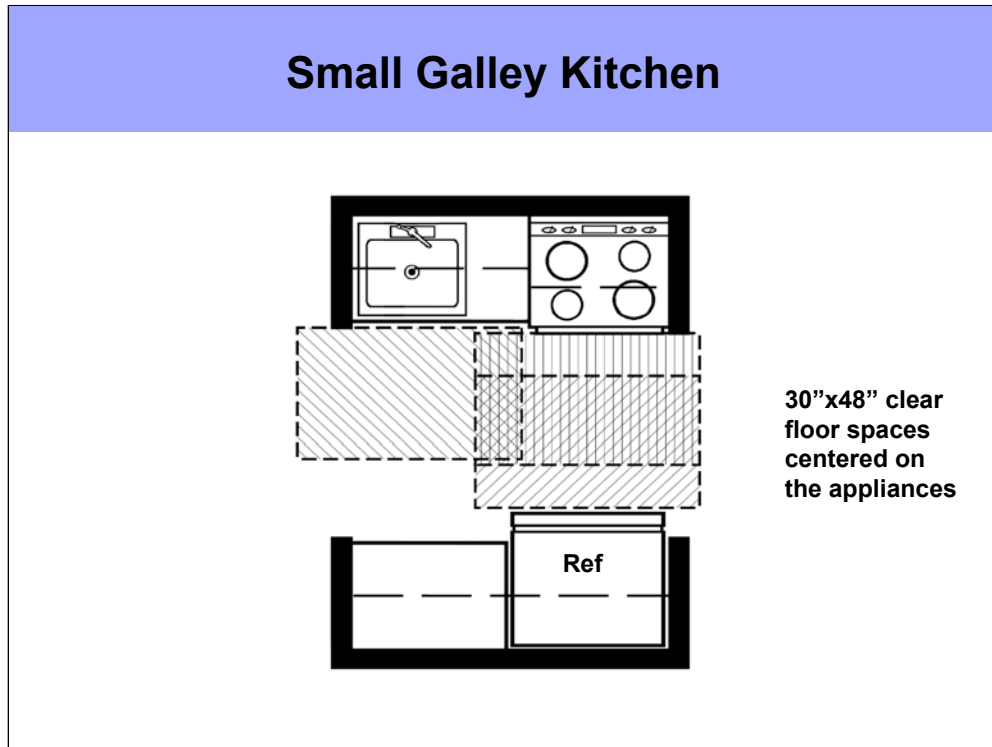

Small Galley Kitchen

A 30"x48" clear floor space, parallel and centered, is provided at the sink, range and refrigerator.

In this compact galley design, the galley must be open at both ends to allow the minimum clear floor spaces to overlap into adjoining spaces, which is allowed.

Notes:

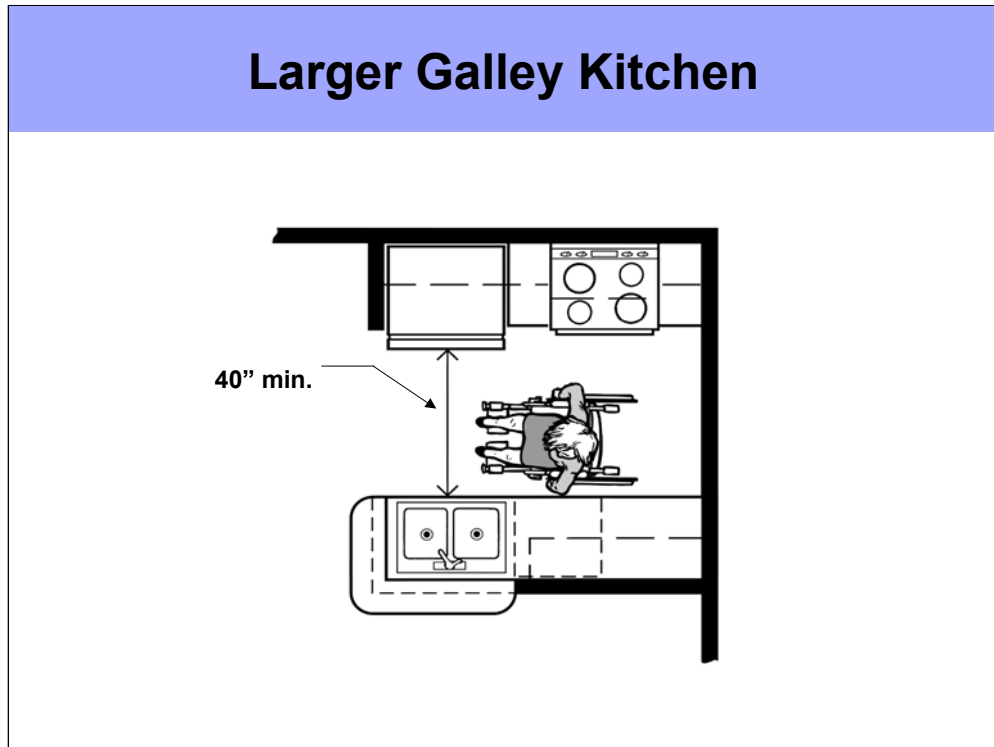

Larger Galley Kitchen

This is a slightly larger galley design, which is commonly seen in many apartment designs.

In this design, the minimum clearance of 40" between countertops must be maintained between the face of the refrigerator and the edge of the opposing countertop.

Notes:

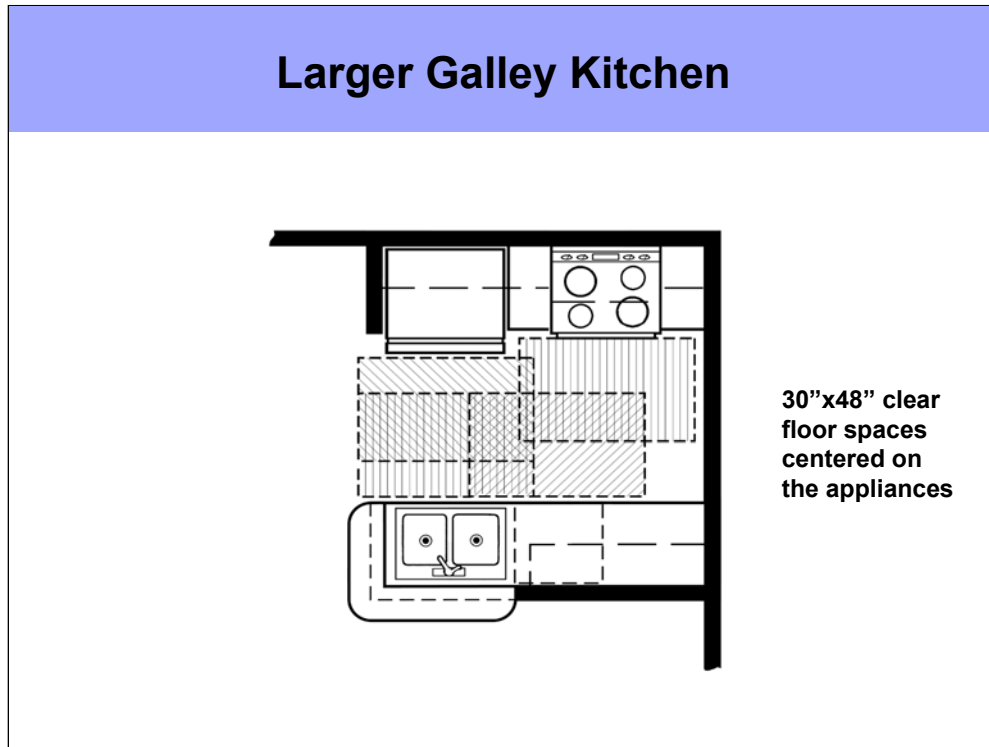

Larger Galley Kitchen

A 30"x48" clear floor space parallel-to and centered-on the range is possible because a cabinet is located between the range and the adjacent sidewall.

At the refrigerator, kitchen sink, and dishwasher, a 30"x48" for a parallel approach is also provided.

When the refrigerator is positioned on the open end of a kitchen, the door may open 180 degrees. While this is not required it allows a close parallel approach to the racks, enhancing access to most of the interior of the refrigerator.

Notes:

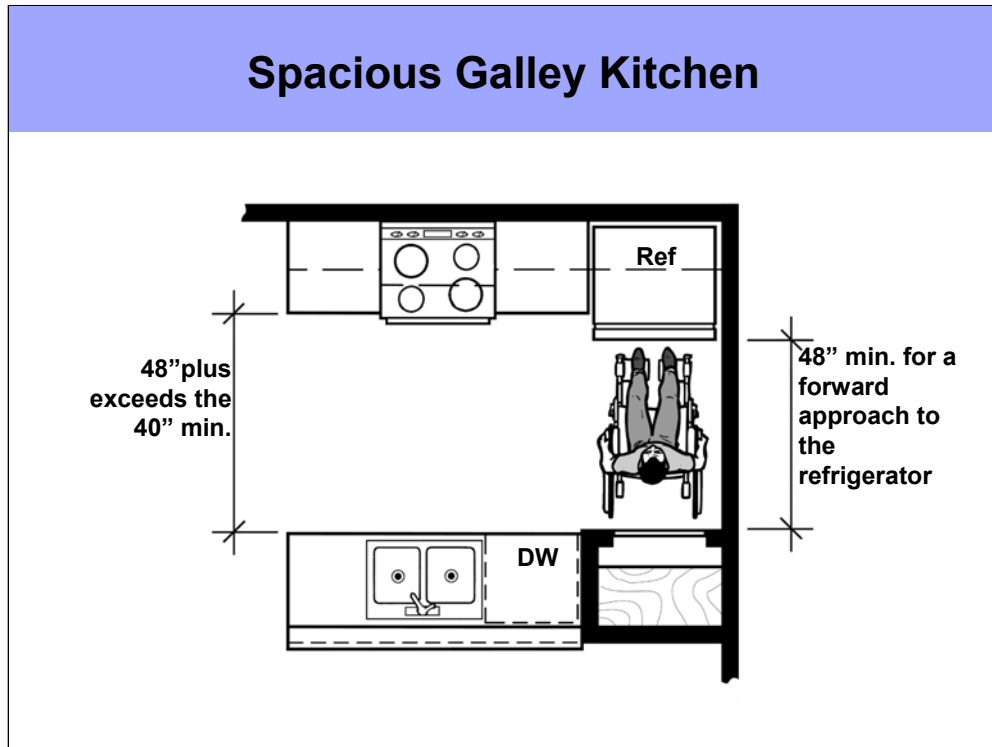

Spacious Galley Kitchen

A larger galley kitchen design found in apartments, condominiums and other types of housing.

Note that because the refrigerator is located against an adjacent sidewall, that a parallel 30"x48" clear floor that is centered is not possible. A typical refrigerator is 32"–36" wide, leaving only approximately 16"–18" from the centerline of the refrigerator to the sidewall. Here the clear floor space must be a 30"x48" perpendicular to the refrigerator. The 48" dimension between the refrigerator and opposing cabinet determine the overall width of the kitchen.

Notes:

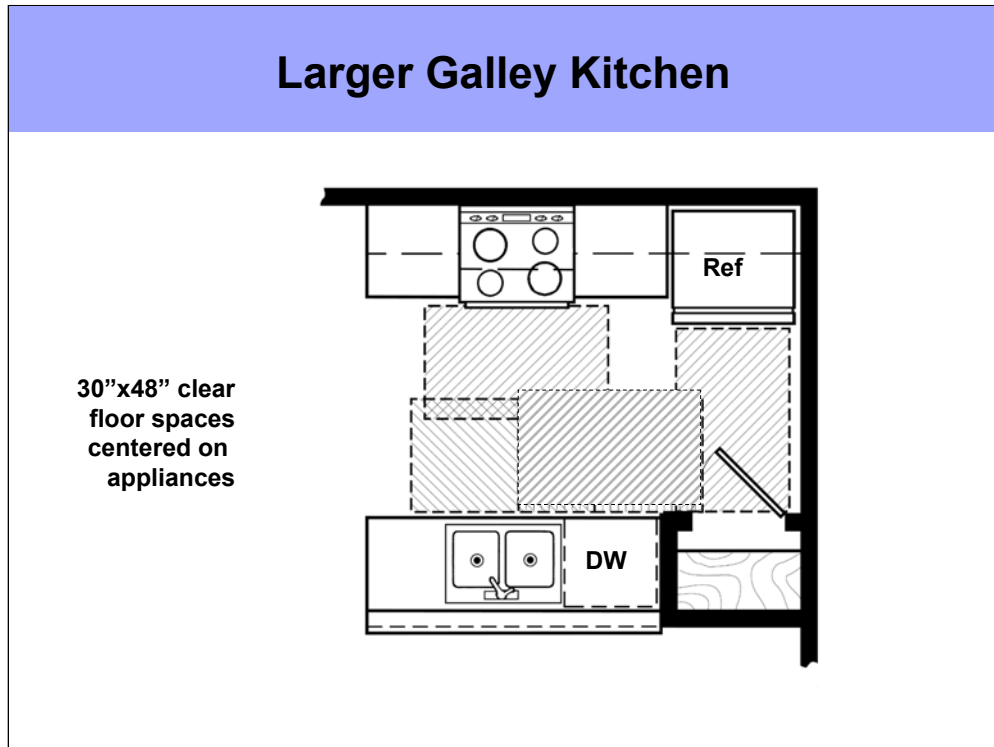

Larger Galley Kitchen

30"x48" clear floor spaces at ranges, sinks, and dishwashers are easily accommodated.

Notes:

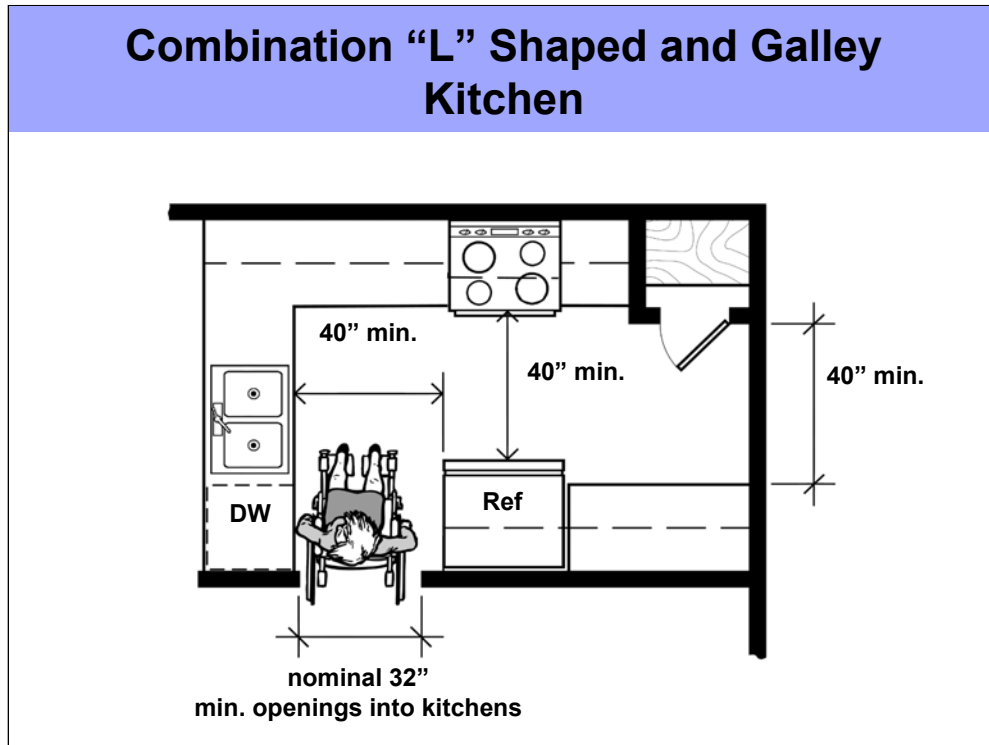

Combination "L" Shaped and Galley Kitchen

This is a combination L and galley design kitchen.

When designing more complex configurations, careful attention must be given to both clearance between cabinets and appliances **and** clear floor space at appliances.

At the entrance to the kitchen illustrated above, a nominal 32" opening (treated like a door) is provided. Once inside the kitchen there is 40" between the side of the refrigerator and the opposing dishwasher. There must also be 40" between face of the refrigerator and the face of the opposing range.

Notes:

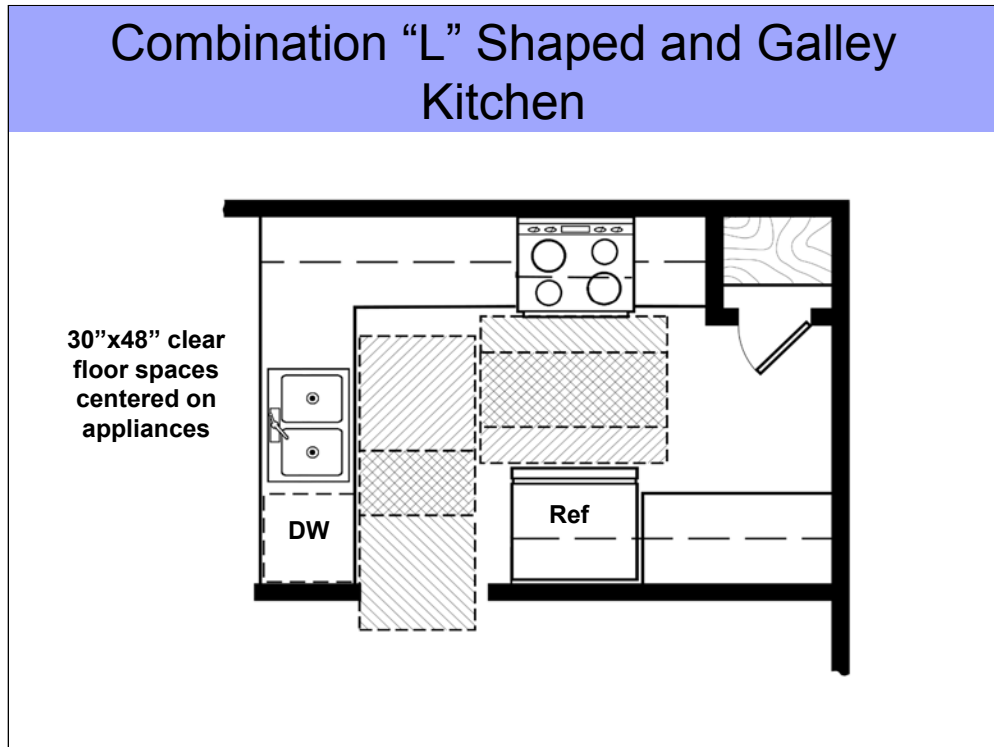

Combination “L” Shaped and Galley Kitchen

As this diagram illustrates, clear floor space at appliances may overlap.

Notes:

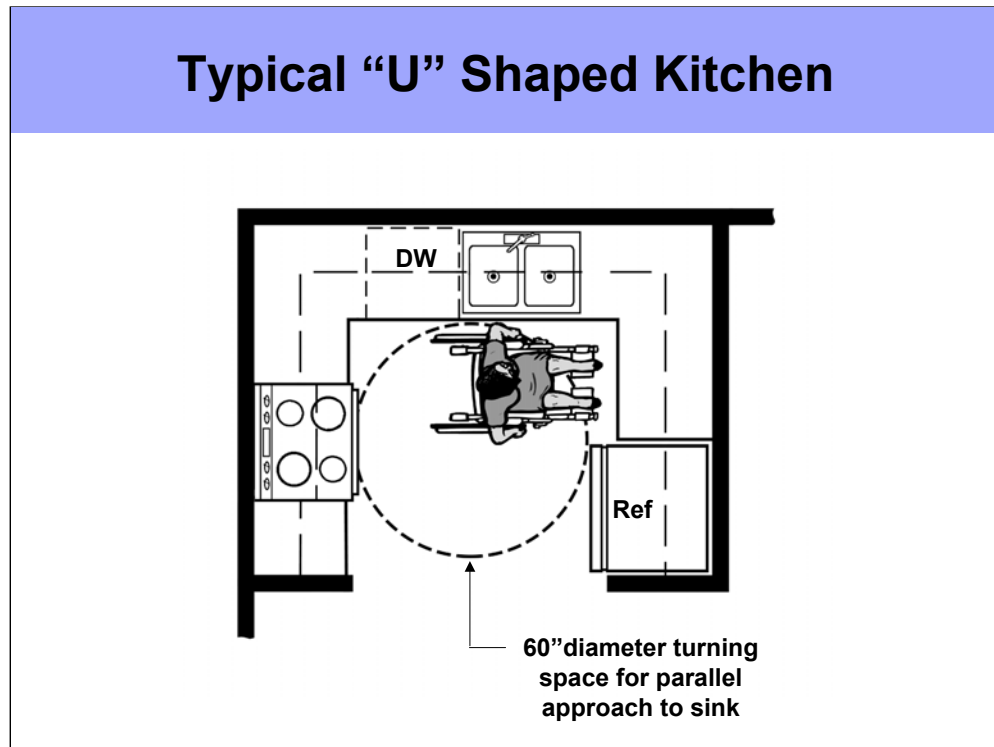

Typical "U" Shaped Kitchen

A typical U-shaped kitchen with a sink and a dishwasher located at the base of the U.

Because there is a sink located at the base of the U, there must be a minimum of a 60" diameter maneuvering space for a person using a wheelchair to position their chair for a close parallel approach to the sink.

In these types of designs, it is critical to take into account the depth of appliances. Refrigerators always protrude beyond the face of a typical 24" deep cabinet, and many times ranges do too. Specifically, in this design, there must be a minimum of 60" from the face of the refrigerator to the face of the opposing range.

Clear floor space must then be provided at appliances and fixtures.

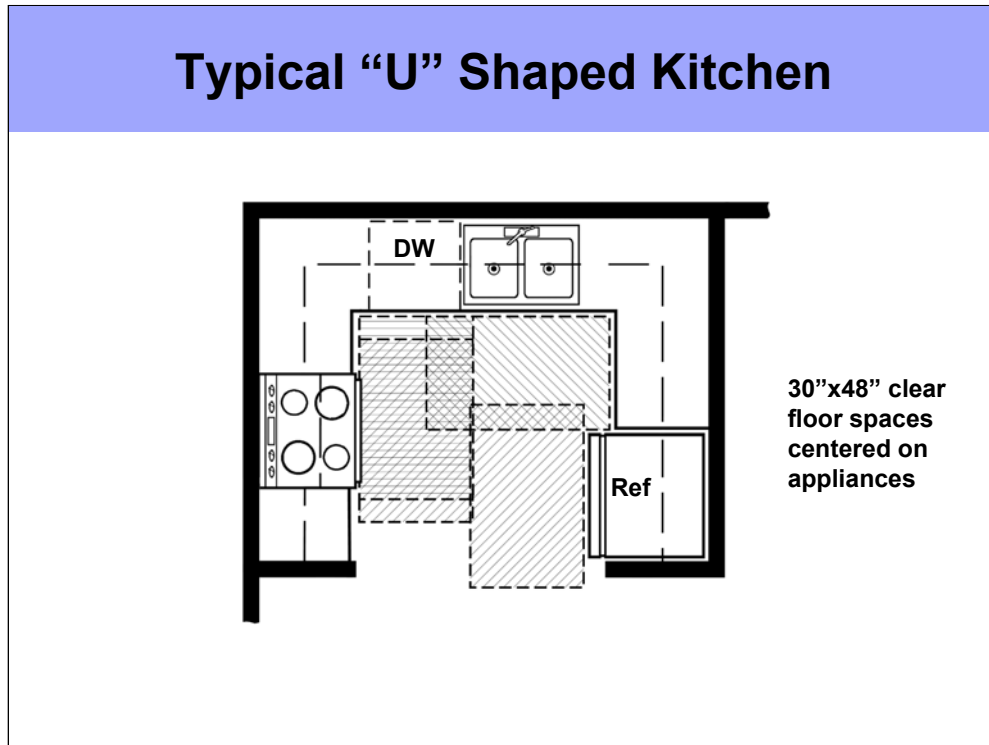

Typical "U" Shaped Kitchen

In this design, the centerline of the kitchen sink must be positioned 24" from the face of the adjacent cabinet. The resultant parallel approach to the sink allows a forward approach to the dishwasher baskets when the door to the dishwasher is pulled down for loading.

To meet clear floor space requirements, the dishwasher has a 30"x48" clear floor space for a forward approach.

Because the range is located in the middle of the length of cabinets, a 30"x48" clear floor space area, parallel-to and centered-on the appliances is easily achieved.

And likewise with the refrigerator, a 30"x48" clear floor space, parallel-to and centered-on, is easily achieved.

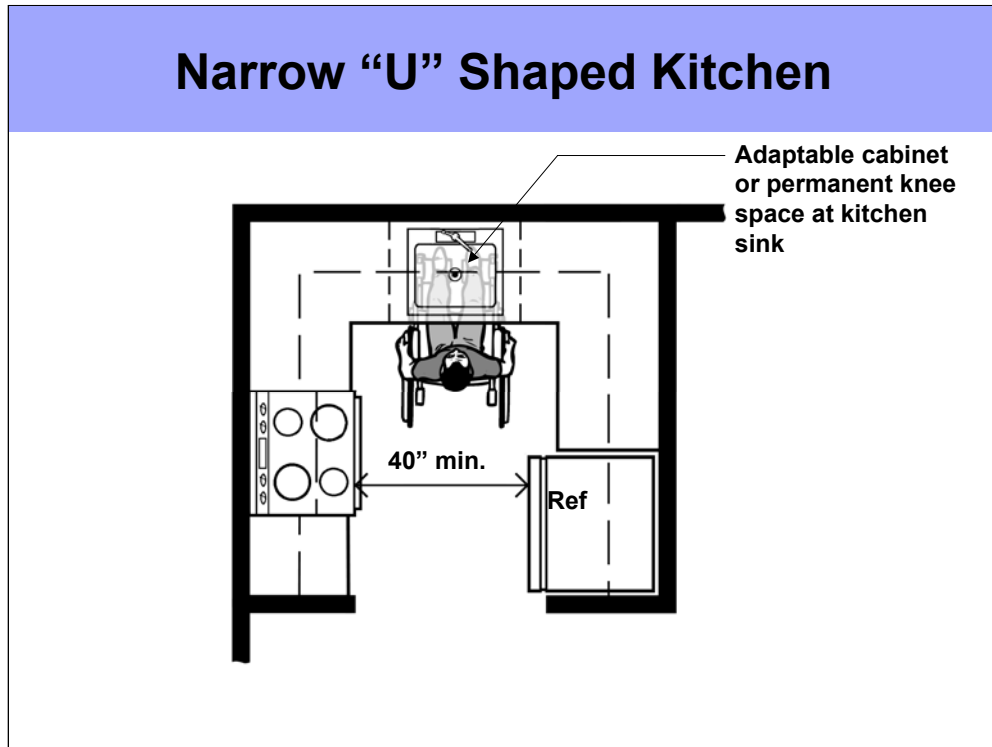

Narrow "U" Shaped Kitchen

This is a very small efficiency-type kitchen. The overall size is kept to a minimum by providing knee space under the sink at the base of the U. This knee space may be permanent or adaptable cabinets may be used.

The key dimension is the 40" minimum clearance between the refrigerator door face and the door face of the opposing range. Once again the refrigerator extends beyond the face of the cabinets and will determine the ultimate width of the kitchen.

The depth of refrigerators are rarely known during the design process, and refrigerators are often changed out over the life-span of the unit. Designers must anticipate a range of typical refrigerator depths, and should design clearances to accomplish the models with greater depths.

Clear floor space at fixtures must be provided at appliances and the kitchen sink.

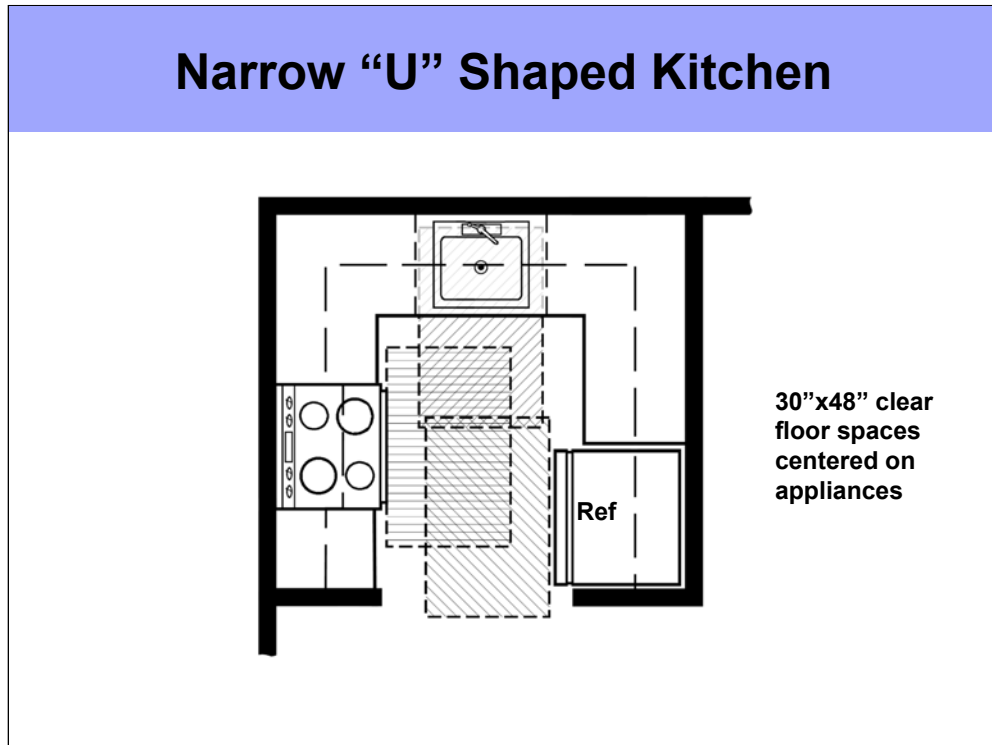

Narrow "U" Shaped Kitchen

In this compact narrow U-shaped design, because there is not a 60" maneuvering space provided within the U, there must be a 30"x48" clear floor space for a forward approach to the sink. The clear floor space must extend 17" min. to 19" max. under the sink.

A 30"x48" clear floor space area parallel-to and centered-on the refrigerator is provided.

A 30"x48" clear floor space parallel-to and centered-on the range is provided. Note that when the oven door is down, the only space available to approach the oven racks is from outside the kitchen, which is allowed.

Notes:

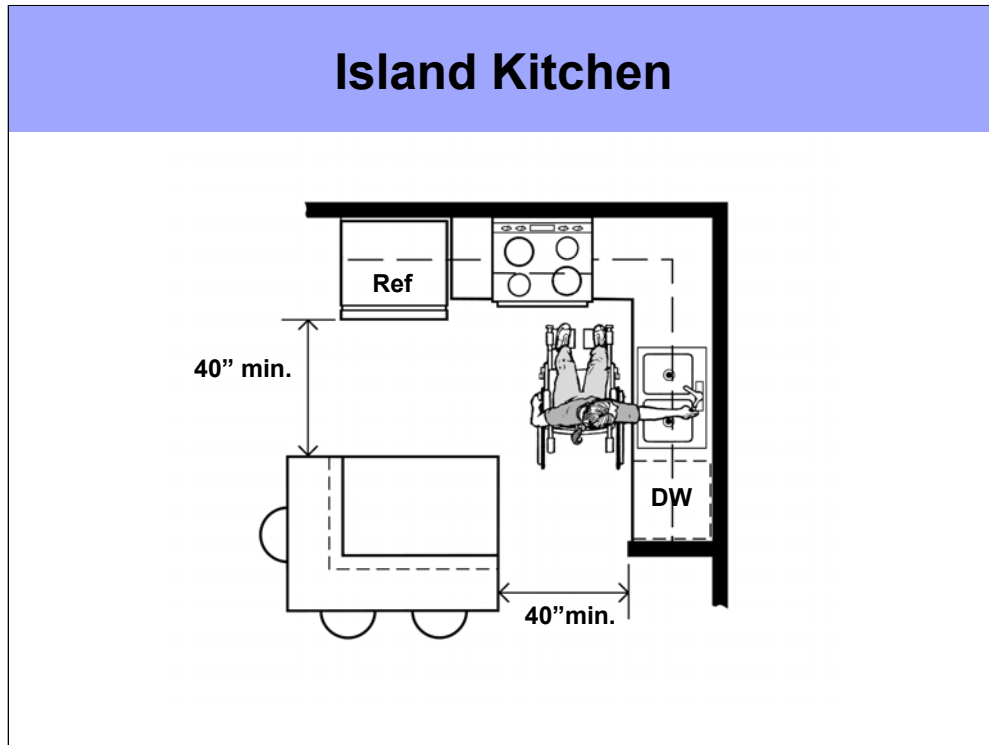

Island Kitchen

Islands are very popular features in many apartment and condominium units. Once again, the key dimension is the 40" minimum clearance between the island, both the end and the working side, and opposing countertops and appliances. Allowance for depth in the refrigerator is crucial. Typical residential refrigerators may range from 27"-34" deep.

As in the other designs discussed, once critical clearance issues are identified, clear floor space at appliances and the kitchen sink must be considered.

Notes:

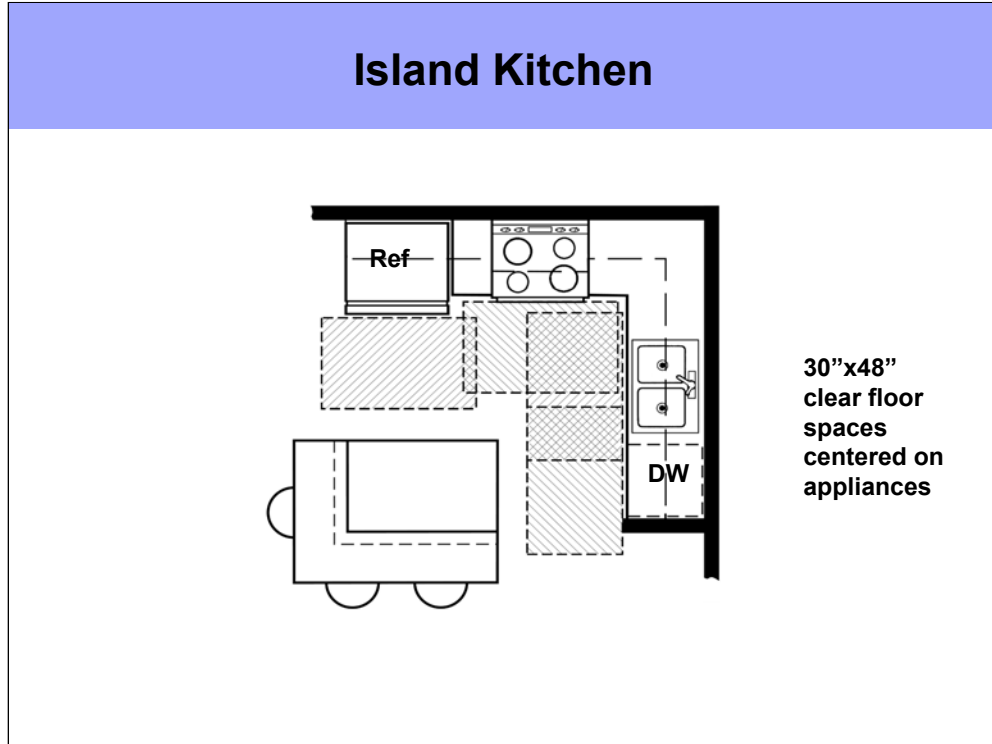

Island Kitchen

In a modest sized design, there is a 30"x48" clear floor space parallel-to and centered-on the refrigerator, range, sink, and dishwasher.

Note that the 30"x48" clear floor space at the refrigerator and dishwasher must overlap into adjoining spaces. This is allowed, but designers must make sure that enclosing walls at the end of the kitchen cabinets do not obstruct access to adjacent appliances.

Notes:

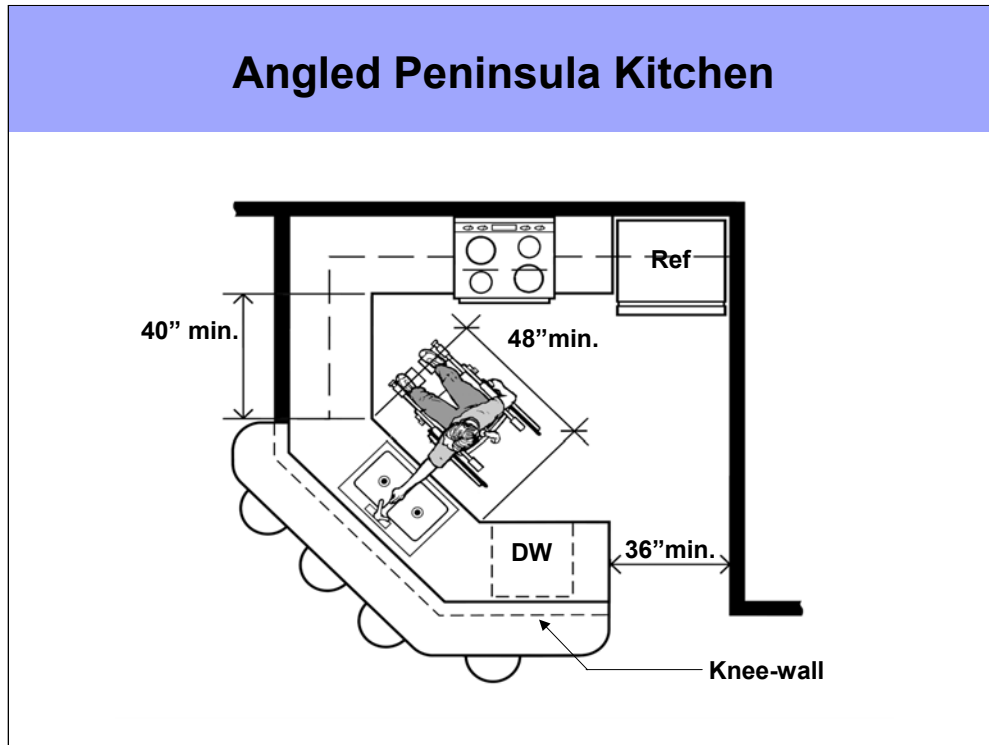

Angled Peninsula Kitchen

Angled peninsula designs are a popular feature in many apartments and condominium units. Some of the critical clearance and clear floor space requirements in this design are:

1. The length of cabinets that extend between the angled sink cabinets and the cabinets where the range is located must be 48" minimum in length.
2. The angled section of the peninsula where the sink is located must be 48" minimum in length for a parallel approach to the sink. A 30" minimum length would also be acceptable if knee space or an adaptable cabinet is provided under the sink.
3. The entry into the kitchen must be 36" wide. A 32" entry width is permissible up to 24" in depth, but kitchen cabinets may just exceed 24" in depth. If there is a knee-wall backing the cabinets then the 24" maximum allowed depth will be exceeded.

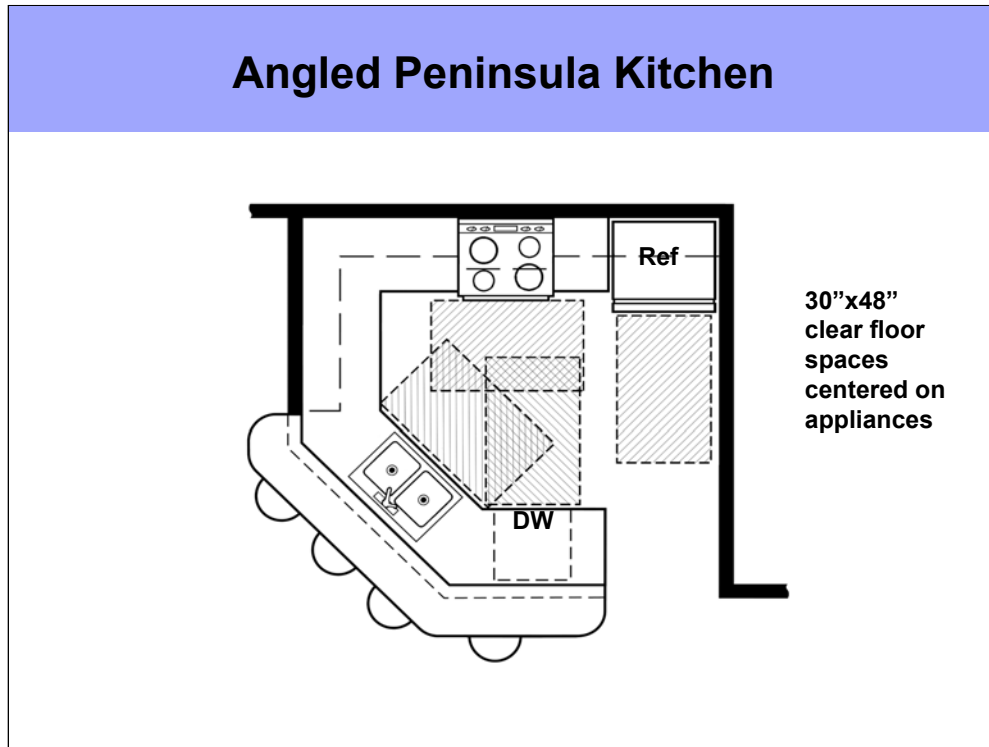

Angled Peninsula Kitchen

In this design, because the range is not located too close to the "L" in the cabinets, there is a 30"x48" clear floor space parallel-to and centered-on the range.

The refrigerator is located against an adjacent side wall. A 30"x48" clear floor space area parallel-to and centered-on the refrigerator is not possible, but a 30"x48" clear floor area for a forward approach is possible.

Notes:

	Strategies for Compliant Kitchens
■	
■	• Overview of the Fair Housing Act
■	• Usable Kitchens Introduction
■	• Usable Kitchens
■	• Resources
■	
■	
■	
■	
■	
■	

Notes:

Fair Housing Accessibility **FIRST**

Fair Housing Accessibility **FIRST**
Information Line
1-888-341-7781 V/TTY



Fair Housing Accessibility **FIRST**
Website
www.FairHousingFIRST.org



Notes:



Comprehensive Training Curriculum

Course Title	Time (hours)
Fair Housing Act Accessibility Requirements Overview	1 (Short) or 4 (Long)
Design and Construction Requirements of the Fair Housing Act: Technical Overview	3
Disability Rights Laws	1.5
Fair Housing Act Enforcement	1.5
Strategies for Compliant Kitchens	1.5
Strategies for Compliant Bathrooms	1.5
Accessible Routes	1.5
Accessible Public and Common Use Areas	1.5
Common Design and Construction Violations and Solutions	1.5
Making Housing Accessible Through Accommodations and Modifications	1.5

**www.FairHousingFIRST.org
(888) 341-7781**



Fair Housing Act and Related Standards

Standard	Where to Obtain
Fair Housing Act as Amended (Title VIII of the Civil Rights Act)	www.FairHousingFIRST.org (888) 341-7781 (V/TTY)
Fair Housing Act Guidelines*	www.FairHousingFIRST.org (888) 341-7781 (V/TTY)
Fair Housing Act Design Manual*	Disseminated at training www.huduser.org (800) 245-2691 TDD: (800) 483-2209
International Building Code*	www.intlcode.org (703) 931-4533
ANSI A117.1 (1986)*	www.intlcode.org (703) 931-4533
CABO/ANSI A117.1 (1992)*	www.bocai.org (800) 214-4321
ICC/ANSI A117.1 (1998)*	www.intlcode.org (703) 931-4533
Code Requirements for Housing Accessibility 2000 (CRHA)*	www.bocai.org (800) 214-4321
Section 504 of the Rehabilitation Act	www.hudclips.org (301) 519-5395
Uniform Federal Accessibility Standards	www.access-board.gov (800) 872-2253, TTY: (800) 872-2253
Architectural Barriers Act of 1968	www.access-board.gov (800) 872-2253, TTY: (800) 872-2253
Americans with Disabilities Act of 1991, Title II and Title III	www.access-board.gov (800) 872-2253, TTY: (800) 872-2253
ADA Accessibility Guidelines	www.access-board.gov (800) 872-2253, TTY: (800) 872-2253

**Denotes HUD Safe Harbor*

Publications

Listed in alphabetical order with the following designations based on topic.

C – Code; D – Design; L – Legal; DA – Disability Advocacy

Type	Resource Name	Description	Where to Obtain
D	Accessible Cabinetry	Describes state-of-the-art cabinetry designed to facilitate use by people with disabilities.	www.design.ncsu.edu/cud/ (800) 647-6777 (voice or TTY)
D	Accessible Environments: Toward Universal Design	Overview of the concept of universal design in everyday environments. Contains design illustrations and history of the disability rights movement.	www.design.ncsu.edu/cud/ (800) 647-6777 (voice or TTY)
D	Accessible Plumbing	Describes state-of-the-art in accessible plumbing fixtures and accessories.	www.design.ncsu.edu/cud/ (800) 647-6777 (voice or TTY)
D	Accessible Stock House Plans Catalog	Contains floor plans and perspectives for six accessible homes.	www.design.ncsu.edu/cud/ (800) 647-6777 (voice or TTY)
D	A Consumer's Guide to Home Adaptation	Includes worksheets for evaluating needs in the home, illustrated construction plans for grab bars, ramps, and other accessible elements, and resource listings for products.	www.design.ncsu.edu/cud/ (800) 647-6777 (voice or TTY)
C	HUD Review of Model Building Codes Final Report		www.hud.gov/offices/ftheo/disabilities/modelcodes/
DA	New Mobility Magazine		www.newmobility.com
L	The New Fair Multifamily Housing: A Design Primer to Assist in Understanding the Accessibility Guidelines of the FHAct	Provides a basic understanding of the accessibility requirements of the FHAct. Also includes illustrated solutions and examples from existing projects.	www.design.ncsu.edu/cud/ (800) 647-6777 (voice or TTY)
L	Rights and Responsibilities of Tenants and Landlords under the Fair Housing Amendments Act	Outlines the rights and responsibilities of tenants with disabilities and landlords under the FHAct.	www.design.ncsu.edu/cud/ (800) 647-6777 (voice or TTY)
D	Tenant's Guide to Apartment Modifications: An Idea Source Pamphlet to Simple, Low-cost Modifications to Increase Accessibility in Apartments	Presents illustrated ideas for low-cost modification that are commonly made to rental dwellings.	www.design.ncsu.edu/cud/ (800) 647-6777 (voice or TTY)

Websites and Organizations

Listed in alphabetical order with the following designations based on topic.

C – Code; D – Design; DA – Disability Advocacy; G – Government; L – Legal; T – Trade ; O – Other

Type	Organization	URL
O	American Association of Retired Persons	www.aarp.org
DA	American Association of People with Disabilities	www.aapd.org
G	Access Board	www.access-board.gov
C	Adaptive Environments	www.adaptenv.org
DA	American Association of People with Disabilities	www.aapd-dc.org
T	American Bankers Association	www.aba.com
T	American Bar Association	www.abanet.org
DA	American Disabled for Attendant Programs Today	www.adapt.org
T	American Institute of Architects	www.aia.org
DA	American Seniors Housing Association	www.seniorshousing.org
T	American Society of Civil Engineers	www.asce.org
T	American Society of Interior Designers	www.asid.org
L	Bazelon Center for Mental Health Law	www.bazelon.org
D	Bob Vila	www.bobvila.com - special features
D	Center for Inclusive Design and Environmental Access	www.ap.buffalo.edu
D	Center for Universal Design	www.design.ncsu.edu/cud/index.html
G	Centers for Medicare and Medicaid Services	www.cms.gov
DA	Consortium for Citizens with Disabilities	www.c-c-d.org
D,L	Cornucopia of Disability Information (CODI)	www.codi.buffalo.edu
G	Department of Agriculture	www.usda.gov
G	Department of Justice	www.usdoj.gov
G	Department of Treasury	www.treasury.gov
DA	Disability Rights Action Coalition for Housing	www.libertyresources.org/housing/nac.html
DA	Eastern Paralyzed Veterans Association	www.epva.org
T	Institute for Real Estate Management	www.irem.org
C	International Code Council	www.intlcode.org
L	The John Marshall Law School Fair Housing Legal Support Center	http://law170.jmls.edu/
D	NAHB Research Center	www.nahbrc.org
T	National Affordable Housing Mgmt. Assoc.	www.nahma.org
T	National Apartment Association	www.naahq.org
T	National Association of Home Builders	www.nahb.org
T	National Association of Realtors	www.nar.realtor.com
T, D	National Association of the Remodeling Industries	www.nari.org
G	National Council on Disability	www.ncd.gov
C	National Conference of States on Building Codes and Standards (NCSBCS)	www.ncsbc.org
DA, L	National Fair Housing Advocate Online	www.fairhousing.com
DA	National Fair Housing Alliance	www.nationalfairhousing.org
D	National Kitchen and Bath Association	www.nkba.org
T	National Low Income Housing Coalition	www.nlihc.org
T	National Multi Housing Council	www.nmhc.org
DA	National Organization on Disability	www.nod.org
D, DA	National Resource Center on Supportive Housing and Home Modification	www.homemods.org
DA	Paralyzed Veterans of America	www.pva.org
D	Technical Assistance Collaborative	www.toolbase.org
DA	Wemedia	www.wemedia.com
DA	World Institute on Disability	www.wid.org